

Parts List			
TCI Part #	Description	Quantity	Item #
13572	Lug Two 350 kcmil	6	1
2401	Hex Hd Bolt 1/2-13 X 1 1/2 In	12	2
1610	Nut 1/2-13	12	3
1512	Flat Washer 1/2"	24	4
1511	Split Lock Washer	12	5
27708	Bus Bar	6	6
14928	Lug Two 2/0	1	7
2934	Hex Hd Bolt 1/4-20 X 3/4 In	1	8
1505	Nut 1/4-20	1	9
1763	Flat Washer 1/4"	1	10
11658	Star Washer 1/4"	1	11

Lug Kit Part #LK04

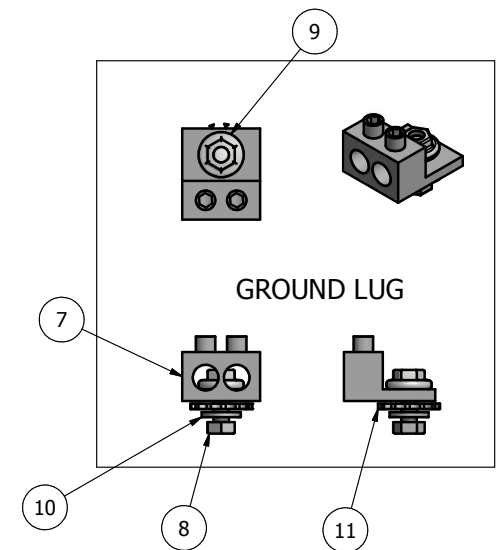
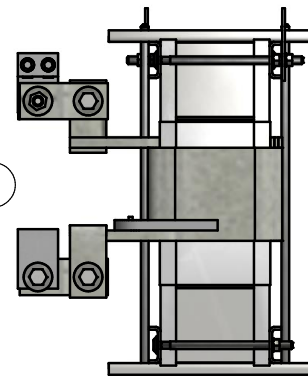

Notes:

- 1.) Torque lug bolts (Item #2) to 450 in-lb (51 N-m).
 - 2.) Torque bolt (Item #7) to 66 in-lb (7.5 N-m).
 - 3.) To prevent lug from rotating place lug on backside of tab as shown.
 - 4.) All terminals are rated for aluminum or copper wire.
 - 5.) Power terminal rating, two 350 kcmil to 6 Awg.
 - 6.) Power terminal tightening torque 375 in-lb (42 N-m).
 - 7.) Ground terminal rating two 2/0 to 14 Awg. Tightening torque Cu 50 in-lbs (5.6 N-m).
 - 8.) Use hole provided in enclosure bottom for mounting.
- CAUTION: To ensure proper bonding lug should be metal to metal contact with enclosure.

Follow NEC guidelines to determine acceptable wire ampacity requirements.

				TOLERANCES (EXCEPT AS NOTED)		W132 N10611 Grant Drive Germantown, WI 53022	
				DECIMAL			
				.XX ± .03		Lug Kit, 2-350MCM-6, And Copper Bus Connector, With Ground, 2-2/0-14	
				.XXX ± .010			
				FRACTIONAL		DRN. BY: DSW	
				± 1/32		DATE: 7/18/16	
				ANGULAR		APRVD: LK04-Dwg	
				± 1°		SCALE: B	
NO	REVISION	DATE	BY			SIZE	SHT. 1 OF 1