

DETAIL G  
SCALE 2 : 1

- 1.) Determine best location where there is adequate ventilation, depth for components, and cables; away from any heat source.
- 2.) The inside surface of the enclosure must be free of protrusions or obstructions in the area where the PQConnect Board will rest.
- 3.) Drill holes as needed per dimension provided.

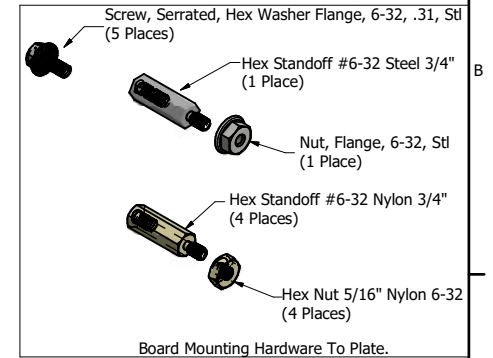

Customer Is Responsible For Installation to Meet All National And Local Electrical Codes.

Material(s) Shall be RoHS Compliant

TCI, LLC CLAIMS PROPRIETARY RIGHTS IN THE MATERIAL HEREIN DISCLOSED. IT IS SUPPLIED WITHOUT PREJUDICE TO ANY PATENT RIGHTS OF TCI AND MAY NOT BE REPRODUCED OR USED TO MANUFACTURE ANYTHING SHOWN THEREIN WITHOUT WRITTEN PERMISSION FROM TCI.					TOLERANCES (EXCEPT AS NOTED)	W132 N10611 Grant Drive Germantown, WI 53022 <b>PKPQ10, MFC Kit, PQconnect Board \ Mounting Hardware</b>
					DECIMAL	
					.XX ± .03 .XXX ± .01	
					FRACTIONAL	
B	S413, Add Bracket to drawing	10/19/2020	DSW		± 1/32	OWN BY: DSW DATE: 9/22/2020 PKPQ10
A	As Designed	9/22/2020	DSW		ANGULAR	SCALE: 1:1
NO	REVISION	DATE	BY		± 1°	1 1