

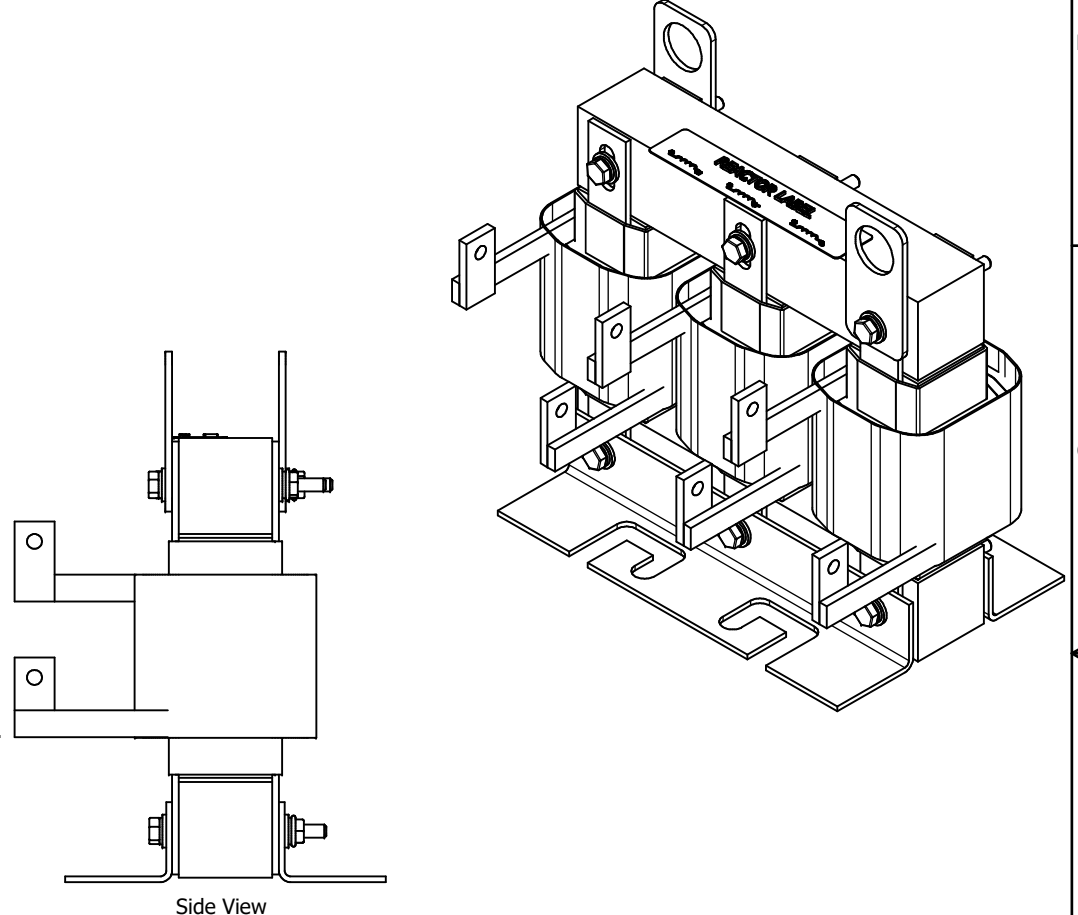

480 Rated Voltage, 600 Max Voltage, Output						
Part Number	Horsepower (HP)	Maximum Amps (A)	---uH+/-10%	Weight (LBS)	Losses (W)	Terminal Hole Size (Inches)
KLR160DCB	150	150	165	35	261	0.28



Markings on coil for reference only.

Material(s) Shall be RoHS Compliant

THE INFORMATION AND DESIGNS CONTAINED IN THIS DRAWING ARE CONFIDENTIAL AND THE PROPRIETARY PROPERTY OF ALLIED MOTION TECHNOLOGIES INC. AND ITS SUBSIDIARIES. NEITHER THIS DESIGN NOR ANY INFORMATION CONTAINED IN THIS DRAWING MAY BE REPRODUCED OR DISCLOSED TO OTHERS WITHOUT THE EXPRESS WRITTEN CONSENT OF ALLIED MOTION TECHNOLOGIES INC. AND ITS SUBSIDIARIES.				TOLERANCES (EXCEPT AS NOTED)		 W132N10611 (Rev 13 Feb 2024) Germantown, WI 53022 © 2024 TCI, LLC	
				DECIMAL			.XX ± .25 .XXX ± .10
				FRACTIONAL			± 1/32
				ANGULAR			± 1°
NO	REVISION	DATE	BY	6561 Was KLR-25 3/6/2024 DSW	480V, 150HP, 3 Phase, UL Recognized KLR160DCB KLR25-2DG	DWN BY: DSW DATE: 3/6/2024 SCALE: 1:1.8 DESIGNED BY: DSW CHECKED BY:	