

Part Number	Horsepower (HP)	Amps (A)	--uH +/-10%	Losses (W)	Weight (LBS)	Terminal Hole Size (Inches)
KLR110ECB	100	110	400	259	75	0.28

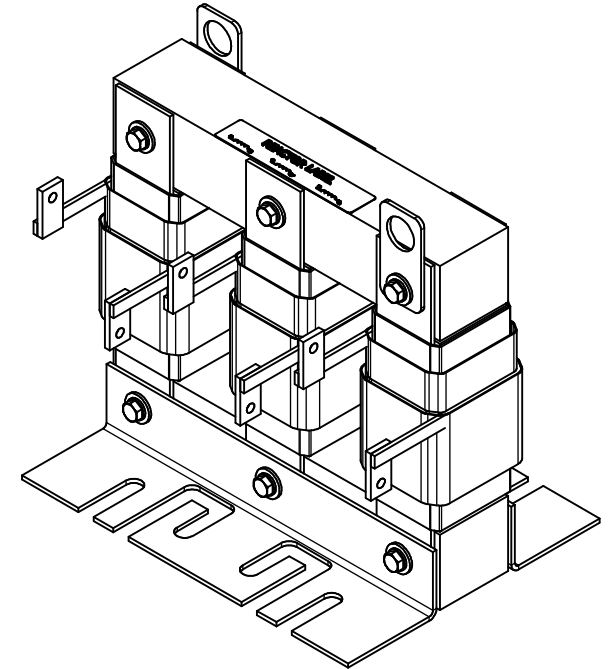

(Customer Connections)
Markings On Coils
For Reference Only.

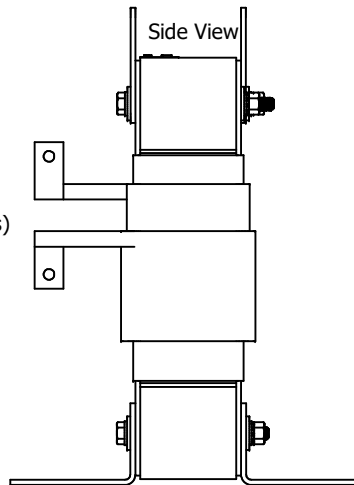
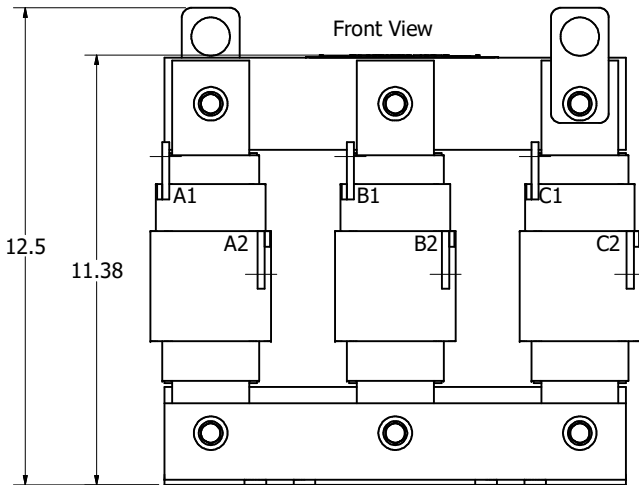
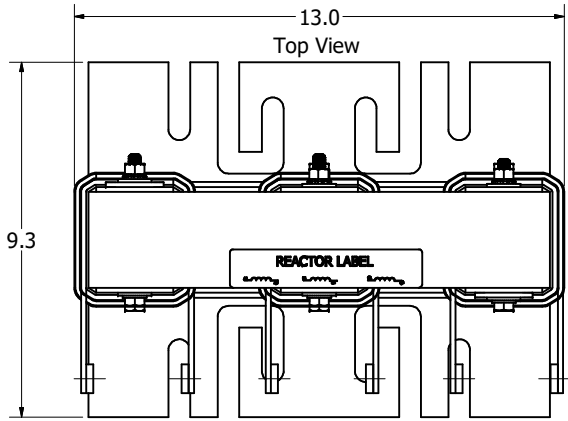
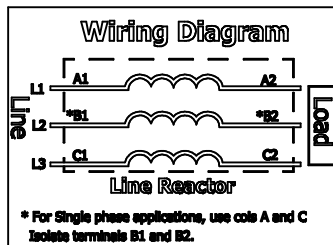
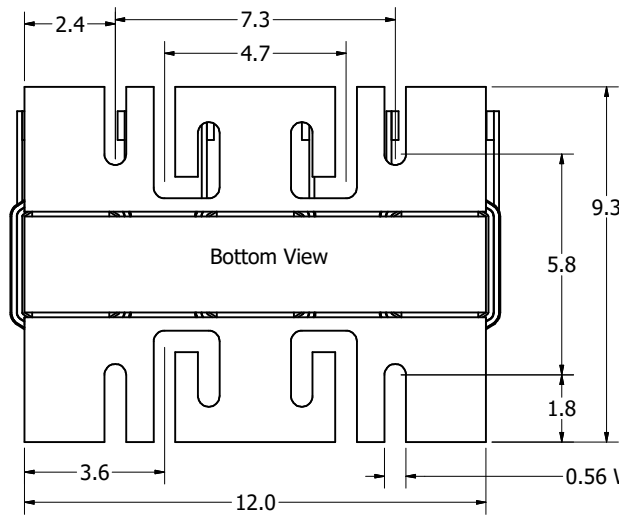

Customer Is Responsible For Installation
To Meet All National And Local Electrical Codes.

Material(s) Shall be RoHS Compliant

THE INFORMATION AND DESIGNS CONTAINED IN THIS DRAWING ARE CONFIDENTIAL AND THE PROPRIETARY PROPERTY OF ALLIED MOTION TECHNOLOGIES INC. AND ITS SUBSIDIARIES. NEITHER THIS DESIGN NOR ANY INFORMATION CONTAINED IN THIS DRAWING MAY BE REPRODUCED OR DISCLOSED TO OTHERS WITHOUT THE EXPRESS WRITTEN CONSENT OF ALLIED MOTION TECHNOLOGIES INC. AND ITS SUBSIDIARIES.				TOLERANCES (EXCEPT AS NOTED) DECIMAL .XX ± .25 .XXX ± .10 FRACTIONAL ± 1/32 ANGULAR ± 1°		 W132N10611 (Rev 13 Feb 2024) Germantown, WI 53022 © 2024 TCI, LLC KLR (L Frame) Reactor Drawing KLR-91-2DG SHT 1 OF 1	
NO	REVISION	DATE	BY	6591, Bus Bar to Flag 32766	3/6/2024	DSW	DRN BY: DATE: 03/16/98
				SCALE: 1/2.5	DRW	DATE: 03/16/98	FILE: KLR-91-2DG