

CATALOG NO	VOLTAGE	NEC MOTOR HP	NEC MOTOR CURRENT	WATTS LOSS	APPROX. WEIGHT-LBS	TORQUE (LB-IN)
KDRULL1LE3R	480	450	515	509	190	SEE BELOW

LUG WIRE RANGE TWO 600MCM-2, AL. OR CU. FOR REACTOR.
TIGHTENING TORQUE. 500 LB-IN

NOTE 1: WATTS LOSS WILL VARY DUE TO FUNDAMENTAL FREQUENCY, CARRIER FREQUENCY AND OTHER SYSTEM CHARACTERISTICS.
KDR DRIVE REACTORS COMPLY WITH THE THERMAL AND ALTITUDE STANDARDS SET FORTH BY NEMA ST20-1992..

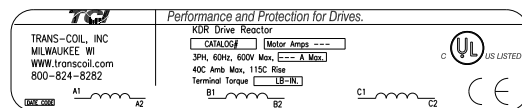

LABEL PLACED ON INSIDE WALL OF CABINET.

NEC MOTOR CURRENTS SHOWN IN THE 208/240 VOLT CHART ARE BASED ON HORSEPOWER AT 208 VOLT. 575/600 VOLT CHART USE THE 575 VOLT CURRENT RATING.

NOTE: ROTATE AS NEEDED TO MEET .50 CLEARANCE BETWEEN TERMINAL OR LUGS (PHASE TO PHASE). ALSO .50 CLEARANCE FROM TERMINALS OR LUGS TO GROUNDING SURFACE.

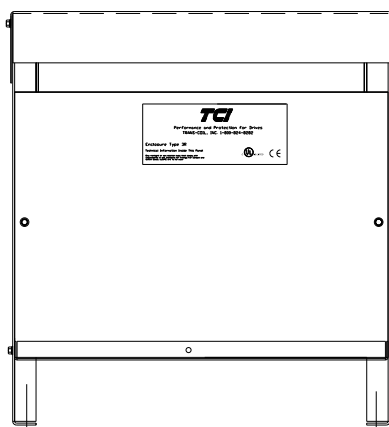
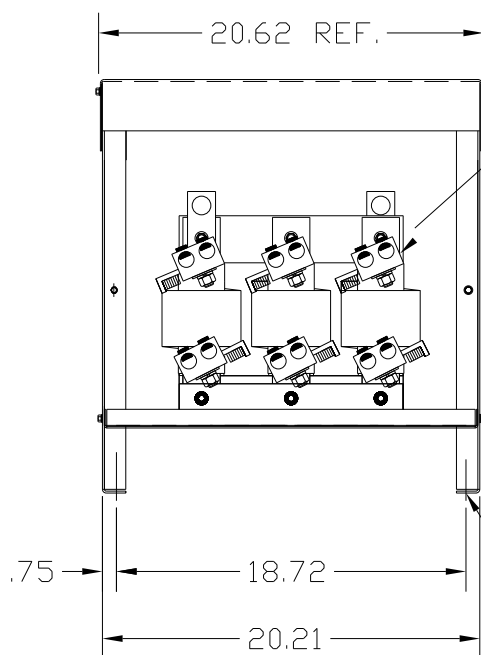

.50 DIA MOUNTING HOLES 4 PLACES.

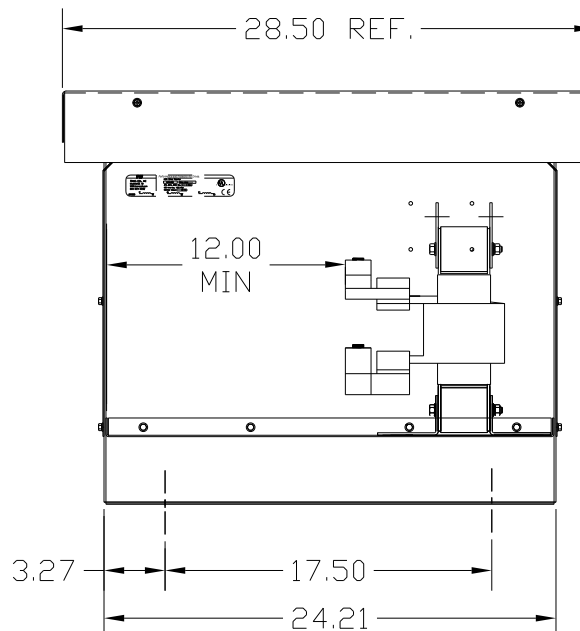

CUSTOMER IS RESPONSIBLE FOR INSTALLATION TO MEET ALL NATIONAL AND LOCAL ELECTRICAL CODES.

FINISH:
VENDOR - LILLY POWDER COATINGS, INC.
PRODUCT CODE - 312E
COLOR - PEBBLE GRAY
POWDER TYPE - POLYESTER-POLYURETHANE

PAINT SUITABLE FOR OUTDOOR APPLICATION PER UL TYPE 3R AND APPLIED PER A UL ACCEPTED DTVV2 COATING PROGRAM.

NOTE: USE ONLY HUBS OR FITTINGS THAT COMPLY WITH UL514B FOR TYPE 3R ENCLOSURES.

				TOLERANCES (EXCEPT AS NOTED)		 7878 N. 86th STREET MILWAUKEE, WI 53224	
				DECIMAL		KDR DRIVE REACTOR 480V, ENCLOSED, TYPE 3R	
				.XX ±.03			
				.XXX±.01			
				FRACTIONAL		DRN BY DSW DATE 8/19/04 DWG. NO. SCALE APRVD KDRULL1LE3RDG	
				± 1/32			
				ANGULAR		SHT. 1 OF 1	
				± 1/2°			
NO	REVISION	DATE	BY				