

CATALOG NO	VOLTAGE	NEC MOTOR HP	NEC MOTOR CURRENT	WATTS LOSS	APPROX. WEIGHT-LBS	TORQUE (LB-IN)
KDRULJ22HE01	208/240	150	396	465	136	275

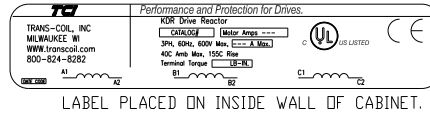
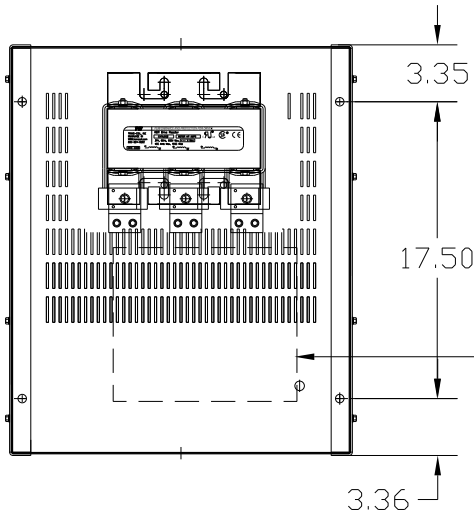

LABEL PLACED ON INSIDE WALL OF CABINET.

LUG WIRE RANGE TWO 350MCM-4, AL. OR CU. FOR REACTOR.
TIGHTENING TORQUE. 275 LB-IN

NOTE 1: WATTS LOSS WILL VARY DUE TO FUNDAMENTAL FREQUENCY, CARRIER FREQUENCY AND OTHER SYSTEM CHARACTERISTICS.
KDR DRIVE REACTORS COMPLY WITH THE THERMAL AND ALTITUDE STANDARDS SET FORTH BY NEMA ST20-1992..

NEC MOTOR CURRENTS SHOWN IN THE 208/240 VOLT CHART ARE BASED ON HORSEPOWER AT 208 VOLT. 575/600 VOLT CHART USE THE 575 VOLT CURRENT RATING.

RECOMMENDED CONDUIT ENTRANCE AREA - LEFT FRONT SIDE, BOTTOM FRONT. RIGHT FRONT SIDE AND TOP.

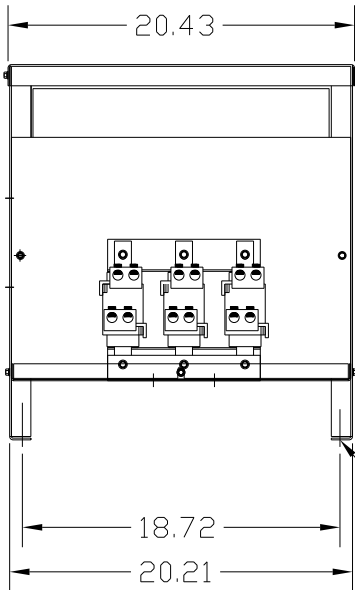

.50 DIA MOUNTING HOLE (4 PLACES)

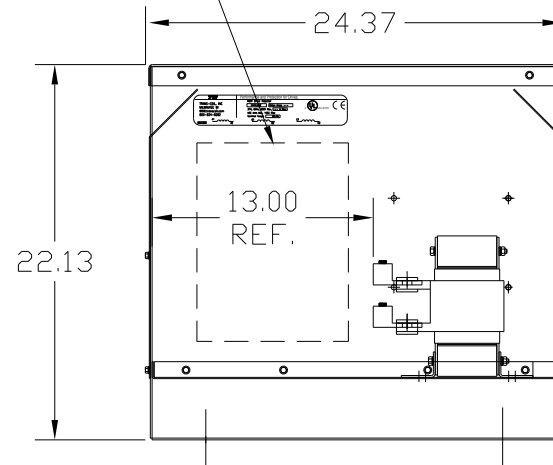
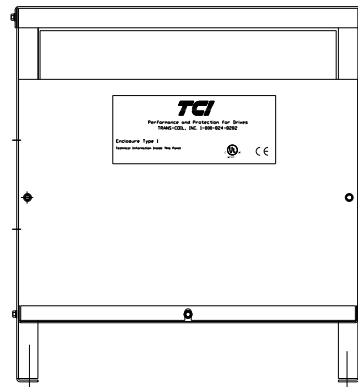

VENDOR LILLY POWDER COATINGS, INC.
PRODUCT CODE 312E
COLOR PEBBLE GRAY
POWDER TYPE POLYESTER POLYURETHANE

PAINT SUITABLE FOR OUTDOOR APPLICATION PER UL TYPE 3R AND APPLIED PER A UL ACCEPTED DTW2 COATING PROGRAM.

CUSTOMER IS RESPONSIBLE FOR INSTALLATION TO MEET ALL LOCAL AND NATIONAL CODES

NO	REVISION	DATE	BY	TOLERANCES (EXCEPT AS NOTED) DECIMAL .XX ± .03 .XXX ± .01 FRACTIONAL ± 1/32 ANGULAR ± 1/2°	 7878 N. 86th STREET MILWAUKEE, WI 53224 KDR DRIVE REACTOR 240V, ENCLOSED, TYPE 1 DRN. BY DSW DATE 6/21/04 DWG. NO. B KDRULJ22HE01DG SCALE APRVD. SHT. 1 OF 1