

LABEL PLACED ON INSIDE WALL OF CABINET.



LABEL PLACED ON FRONT OF CABINET.

RECOMMENDED CONDUIT ENTRANCE AREA - LEFT FRONT SIDE, BOTTOM FRONT. RIGHT FRONT SIDE AND TOP.

CATALOG NO	VOLTAGE	NEC MOTOR HP	NEC MOTOR CURRENT	WATTS LOSS	APPROX. WEIGHT-LBS	TORQUE (LB-IN)
KDRULH3LE01	480	100	124	225	78	275

NOTE 1: WATTS LOSS WILL VARY DUE TO FUNDAMENTAL FREQUENCY, CARRIER FREQUENCY AND OTHER SYSTEM CHARACTERISTICS. KDR DRIVE REACTORS COMPLY WITH THE THERMAL AND ALTITUDE STANDARDS SET FORTH BY NEMA ST20-1992..

NEC MOTOR CURRENTS SHOWN IN THE 208/240 VOLT CHART ARE BASED ON HORSEPOWER AT 208 VOLT. 575/600 VOLT CHART USE THE 575 VOLT CURRENT RATING.

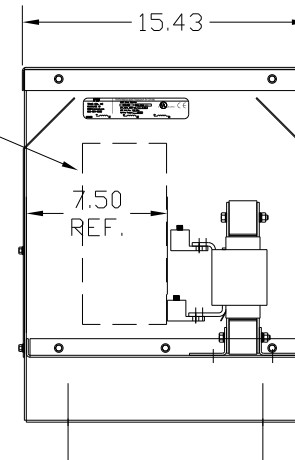
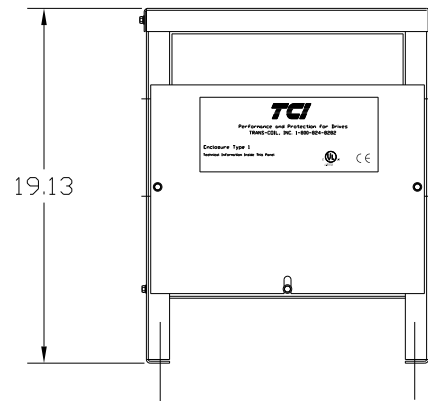
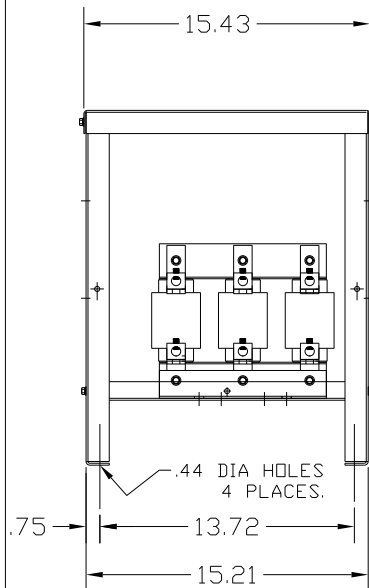

LUG WIRE RANGE 250MCM-6, AL OR CU. FOR REACTOR.
TIGHTENING TORQUE. 275 LB-IN

VENDOR LILLY POWDER COATINGS, INC.
PRODUCT CODE 312E
COLOR PEBBLE GRAY
POWDER TYPE POLYESTER POLYURETHANE

PAINT SUITABLE FOR OUTDOOR APPLICATION PER UL TYPE 3R AND APPLIED PER A UL ACCEPTED DTW2 COATING PROGRAM.

CUSTOMER IS RESPONSIBLE FOR INSTALLATION TO MEET ALL LOCAL AND NATIONAL CODES

NO	REVISION	DATE	BY	TOLERANCES (EXCEPT AS NOTED): DECIMAL .XX ± .03 .XXX ± .01 FRACTIONAL ± 1/32 ANGULAR ± 1/2°	 7878 N. 86th STREET MILWAUKEE, WI 53224 KDR DRIVE REACTOR 480V, ENCLOSED, TYPE 1 <small>DRN. BY DSW DATE 6/21/04 DWG. NO. BKDRULH3LE01DG</small> <small>SCALE APRVD. SHT. 1 of 1</small>