

CATALOG NO	VOLTAGE	NEC MOTOR HP	NEC MOTOR CURRENT	WATTS LOSS	APPROX. WEIGHT-LBS	TORQUE (LB-IN)
KDRULB45LE3R	575/600	15	17	66.2	23	20

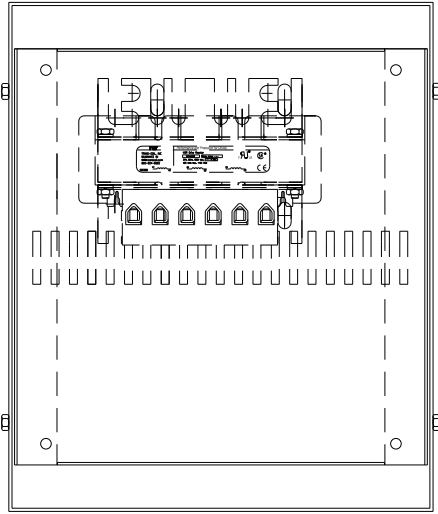

NOTE: A1, A2, B1, B2, C1, C2, MARKINGS ON TERMINAL BLOCK FOR REFERENCE ONLY.

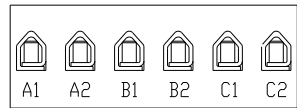

TERMINAL BLK MARKING

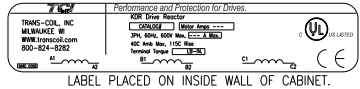

NOTE 1: WATTS LOSS WILL VARY DUE TO FUNDAMENTAL FREQUENCY, CARRIER FREQUENCY AND OTHER SYSTEM CHARACTERISTICS. KDR DRIVE REACTORS COMPLY WITH THE THERMAL AND ALTITUDE STANDARDS SET FORTH BY NEMA ST20-1992..

NEC MOTOR CURRENTS SHOWN IN THE 208/240 VOLT CHART ARE BASED ON HORSEPOWER AT 208 VOLT. 575/600 VOLT CHART USE THE 575 VOLT CURRENT RATING.

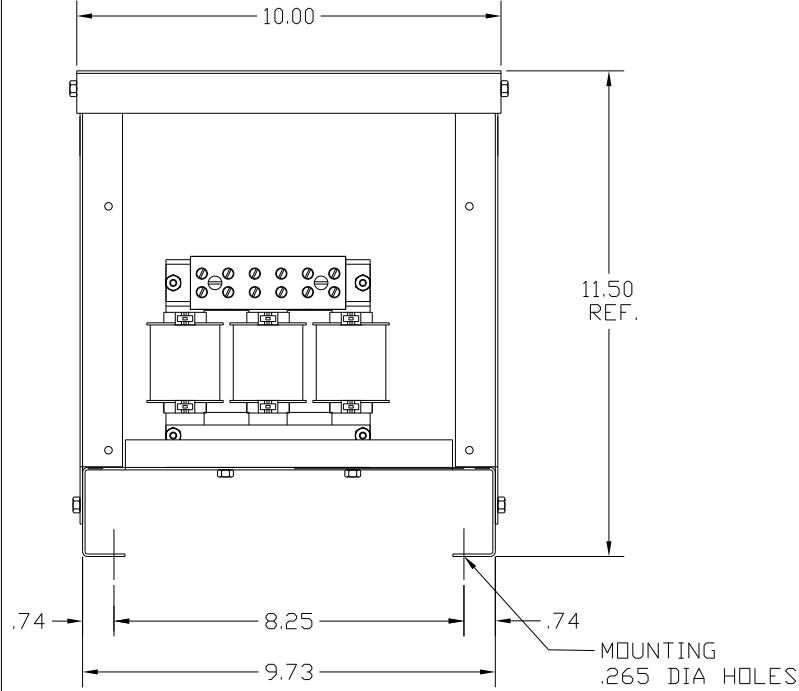

MOUNTING .265 DIA HOLES 4 PLACES

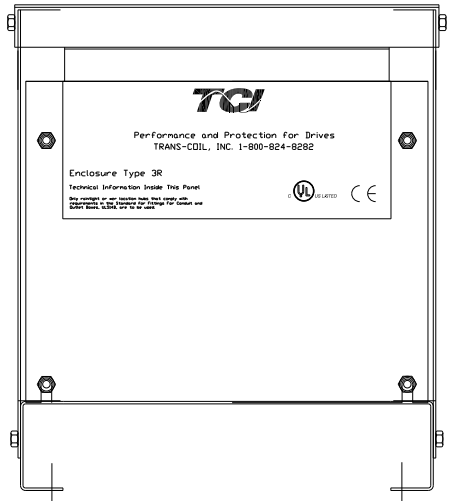

CUSTOMER IS RESPONSIBLE FOR INSTALLATION TO MEET ALL NATIONAL AND LOCAL ELECTRICAL CODES.

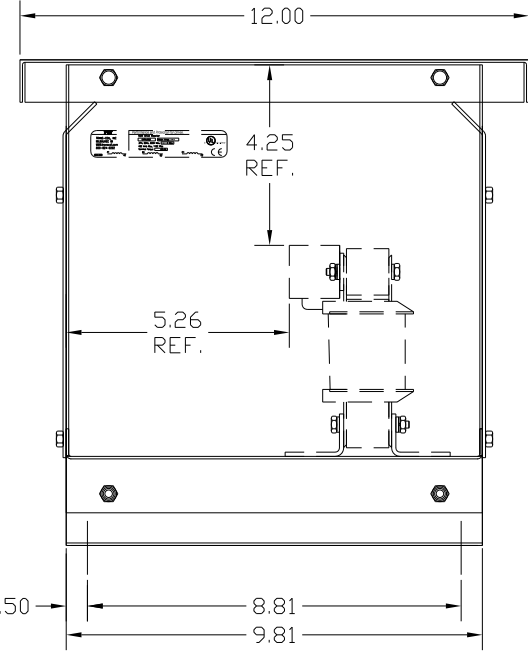

NOTE: USE ONLY HUBS OR FITTINGS THAT COMPLY WITH UL514B FOR TYPE 3R ENCLOSURES.

FINISH:  
 VENDOR - LILLY POWDER COATINGS, INC.  
 PRODUCT CODE - 312E  
 COLOR - PEBBLE GRAY  
 POWDER TYPE - POLYESTER-POLYURETHANE  
 PAINT SUITABLE FOR OUTDOOR APPLICATION PER UL TYPE 3R AND APPLIED PER A UL ACCEPTED DTVV2 COATING PROGRAM.

NO	REVISION	DATE	BY

**TCI** 7878 N. 86th STREET  
 MILWAUKEE, WI 53224

**KDR DRIVE REACTOR**  
 575V, ENCLOSED, TYPE 3R

DRN. BY: DSW DATE: 9/20/04 DWG. NO.: KDRULB45LE3R DG  
 SCALE: APRVD. SHT. 1 of 1