

CATALOG NO	VOLTAGE	NEC MOTOR HP	NEC MOTOR CURRENT	WATTS LOSS	APPROX. WEIGHT-LBS	TORQUE (LB-IN)
KDRULB26HE3R	208/240	7.5	24.2	66.5	23	20

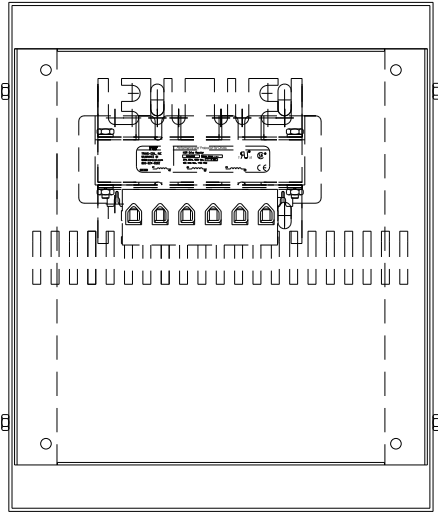

NOTE: A1, A2, B1, B2, C1, C2, MARKINGS ON TERMINAL BLOCK FOR REFERENCE ONLY.

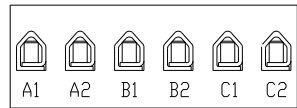

TERMINAL BLK MARKING

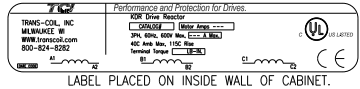

NOTE 1: WATTS LOSS WILL VARY DUE TO FUNDAMENTAL FREQUENCY, CARRIER FREQUENCY AND OTHER SYSTEM CHARACTERISTICS. KDR DRIVE REACTORS COMPLY WITH THE THERMAL AND ALTITUDE STANDARDS SET FORTH BY NEMA ST20-1992..

NEC MOTOR CURRENTS SHOWN IN THE 208/240 VOLT CHART ARE BASED ON HORSEPOWER AT 208 VOLT. 575/600 VOLT CHART USE THE 575 VOLT CURRENT RATING.

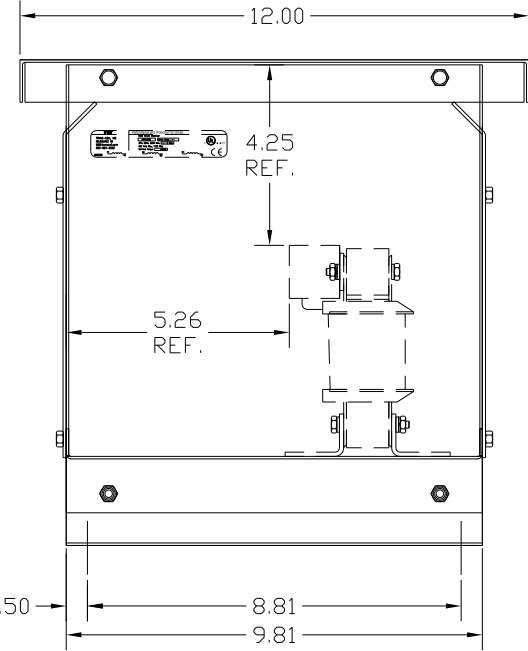
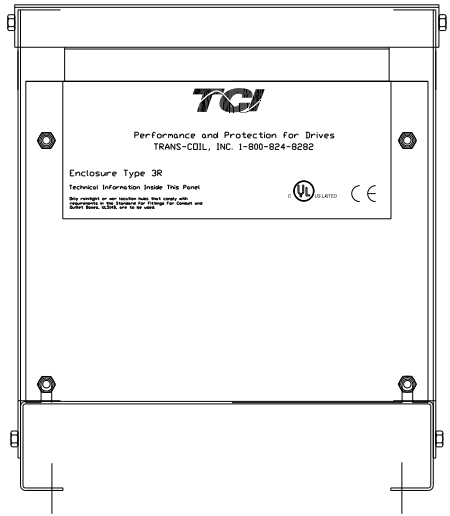
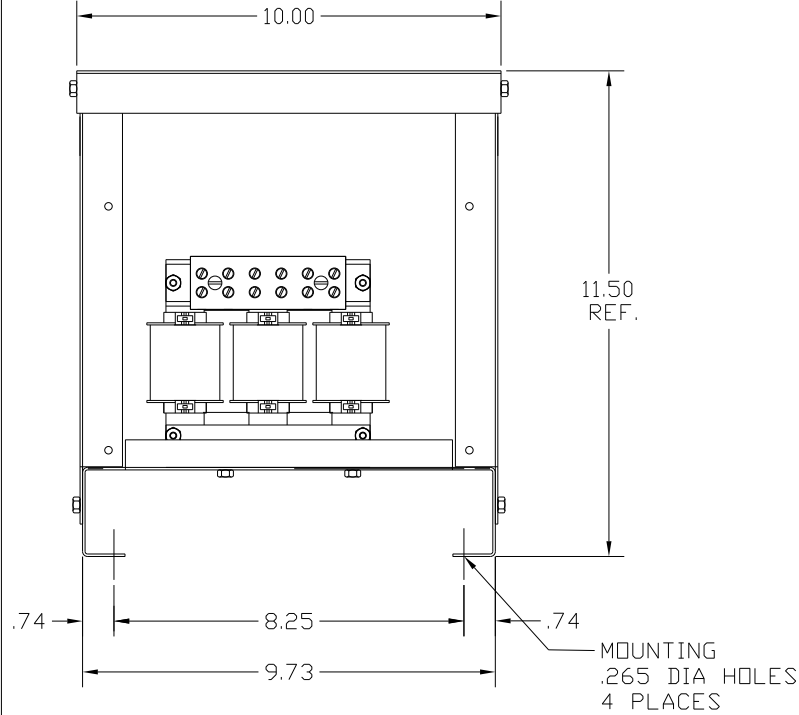

CUSTOMER IS RESPONSIBLE FOR INSTALLATION TO MEET ALL NATIONAL AND LOCAL ELECTRICAL CODES.

NOTE: USE ONLY HUBS OR FITTINGS THAT COMPLY WITH UL514B FOR TYPE 3R ENCLOSURES.

FINISH:  
 VENDOR - LILLY POWDER COATINGS, INC.  
 PRODUCT CODE - 312E  
 COLOR - PEBBLE GRAY  
 POWDER TYPE - POLYESTER-POLYURETHANE  
 PAINT SUITABLE FOR OUTDOOR APPLICATION PER UL TYPE 3R AND APPLIED PER A UL ACCEPTED DTVV2 COATING PROGRAM.

				TOLERANCES (EXCEPT AS NOTED): DECIMAL		7878 N. 86th STREET MILWAUKEE, WI 53224 <b>KDR DRIVE REACTOR</b> <b>240V, ENCLOSED, TYPE 3R</b>
				.XX ± .03		
				.XXX ± .01		
				FRACTIONAL ± 1/32		
				ANGULAR ± 1/2°		
NO	REVISION	DATE	BY	DRN. BY DSW	DATE 9/20/04	DWG. NO. KDRULB26HE3R DG SHT. 1 OF 1