

CATALOG NO	VOLTAGE	NEC MOTOR HP	NEC MOTOR CURRENT	WATTS LOSS	APPROX WT-LBS	TERMINAL HOLE SIZE
KDRJ1HC5	480	200	240	420	120	.44

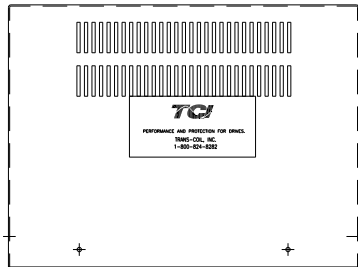

.328 DIA.
2 HOLES

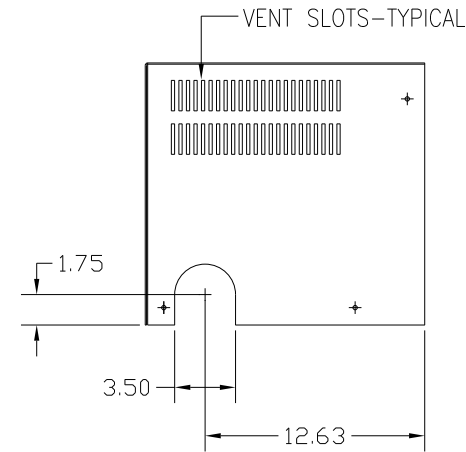
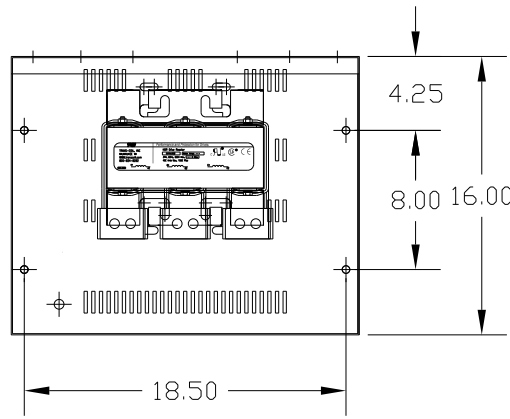
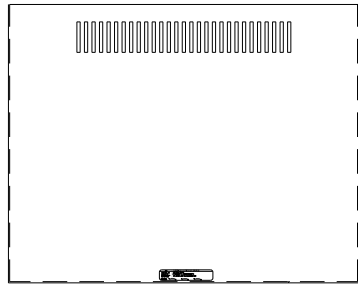
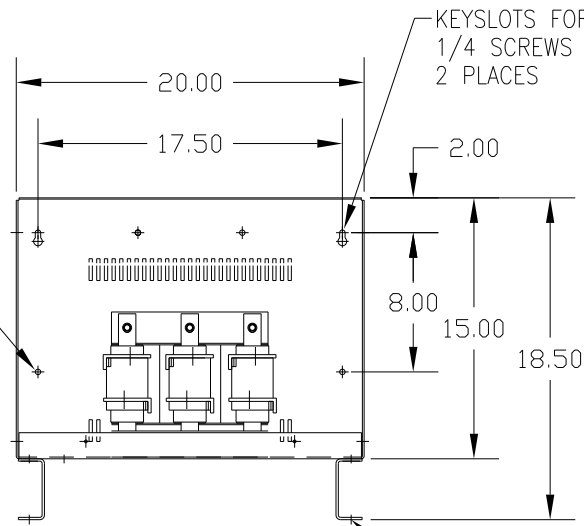

KEYSLOTS FOR
1/4 SCREWS
2 PLACES

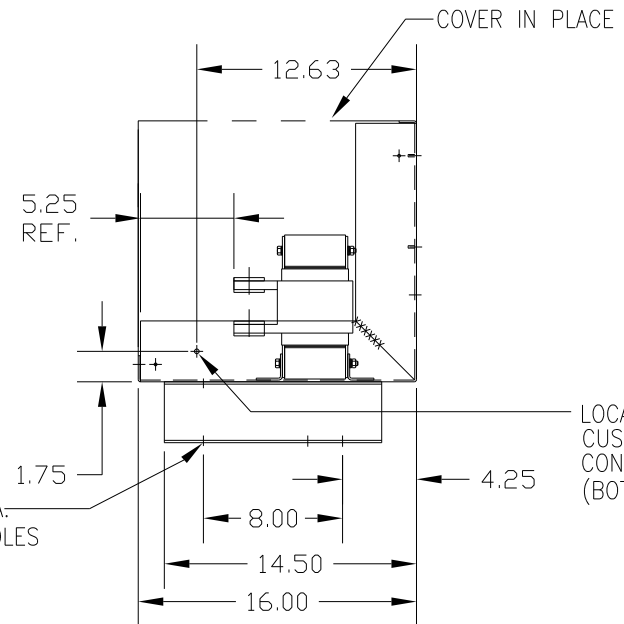

COVER IN PLACE

LOCATION FOR
CUSTOMERS
CONDUIT FITTING
(BOTH SIDES)

.44 DIA.
4 MTG. HOLES

CUSTOMER IS RESPONSIBLE FOR INSTALLATION
TO MEET ALL NATIONAL AND LOCAL ELECTRICAL CODES.

TOLERANCES (EXCEPT AS NOTED)				TCI 7878 N. 86th STREET MILWAUKEE, WI 53224	
DECIMAL				KDR DRIVE REACTOR, ENCLOSED 480V HIGH Z, FRAME J	
.XX ± .03					
.XXX ± .01					
FRACTIONAL ± 1/32					
ANGULAR ± 1/2°				DRN. BY DSW	DATE 2/14/12
NO	REVISION	DATE	BY	SCALE	APRVD. B
					DWG. NO. KDRJ1HC5DG
					SHT. 1 OF 1