

CATALOG NO	VOLTAGE	NEC MOTOR HP	NEC MOTOR CURRENT	WATTS LOSS	APPROX. WEIGHT-LBS	TERMINAL BLOCK TORQUE: (LB-IN)
KDRD25LC2	208/240	10	30.8	64	18	20

NEC MOTOR CURRENTS SHOWN IN THE 208/240 VOLT CHART ARE BASED ON HORSE POWERS AT 208 VOLT. 575/600 VOLT CHART USE THE 575 VOLT CURRENT RATING.

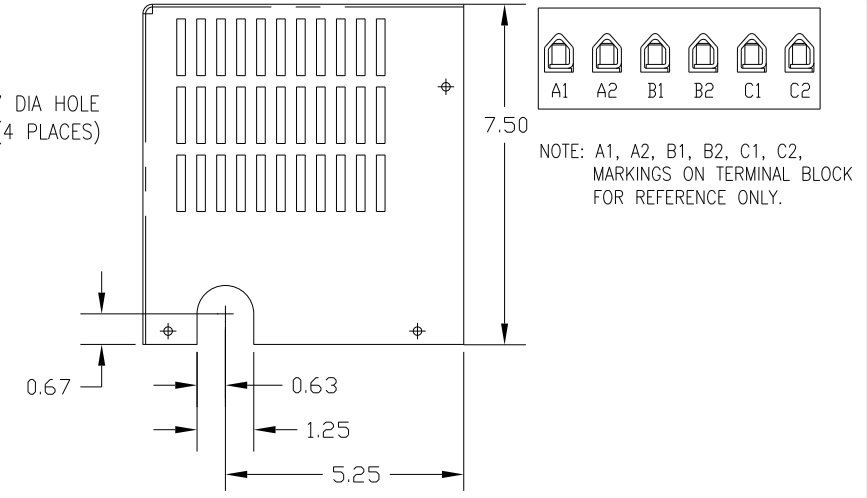

NOTE: A1, A2, B1, B2, C1, C2, MARKINGS ON TERMINAL BLOCK FOR REFERENCE ONLY.

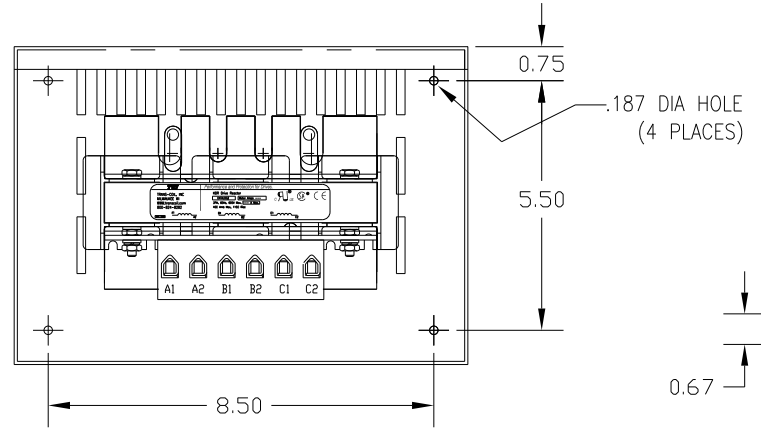
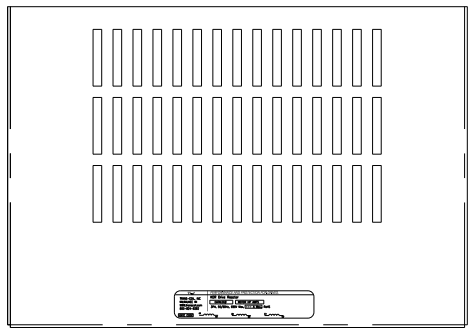
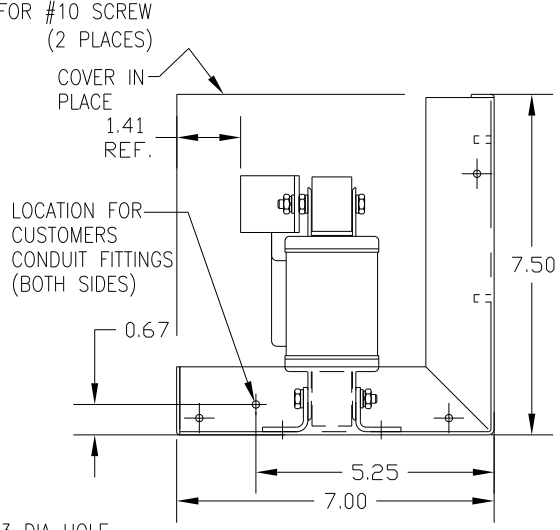
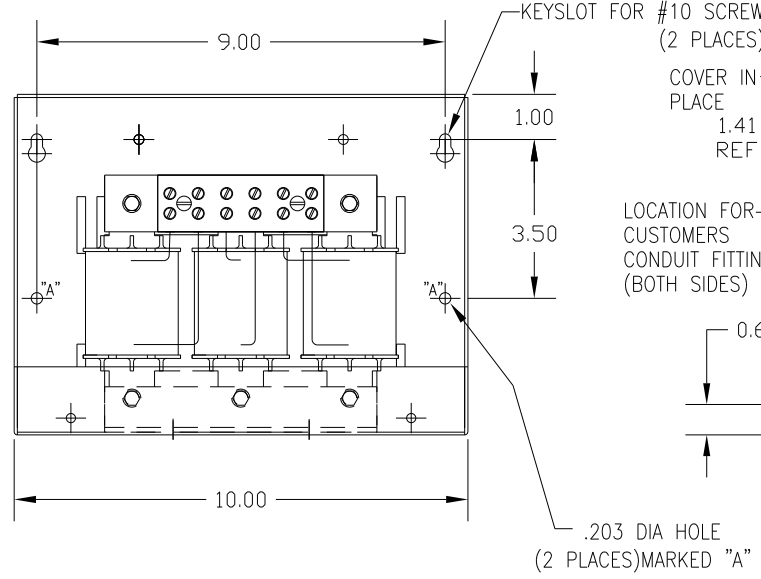
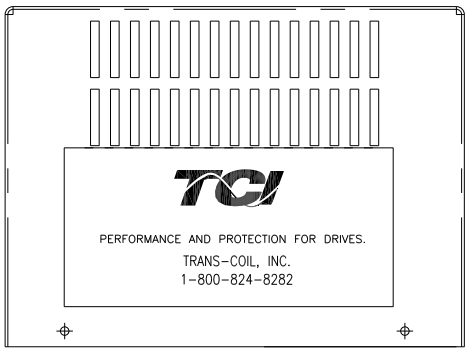

CUSTOMER IS RESPONSIBLE FOR INSTALLATION TO MEET ALL NATIONAL AND LOCAL ELECTRICAL CODES.

				TOLERANCES (EXCEPT AS NOTED)		7878 N. 86th STREET MILWAUKEE, WI 53224	
				DECIMAL			
				.XX ± .03		<b>KDR DRIVE REACTOR</b> <b>240V LOW Z, FRAME D</b>	
				.XXX ± .01			
				FRACTIONAL		DRN BY DSW DATE 1/26/12 DWG. NO. B	
				± 1/32		KDRD25LC2DG	
				ANGULAR		SCALE	
				± 1/2°		APRVD. B SHT. 1 OF 1	
NO	REVISION	DATE	BY				