

CATALOG NO	VOLTAGE	NEC MOTOR HP	NEC MOTOR CURRENT	WATTS LOSS	APPROX WT-LBS
KDRC43LC2	575/600	40	41	109	21

NEC MOTOR CURRENTS SHOWN IN THE 575/600 VOLT CHART ARE BASED ON HORSE POWERS AT 575 VOLT.

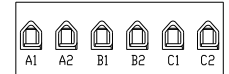

NOTE: A1, A2, B1, B2, C1, C2, MARKINGS ON TERMINAL BLOCK FOR REFERENCE ONLY.

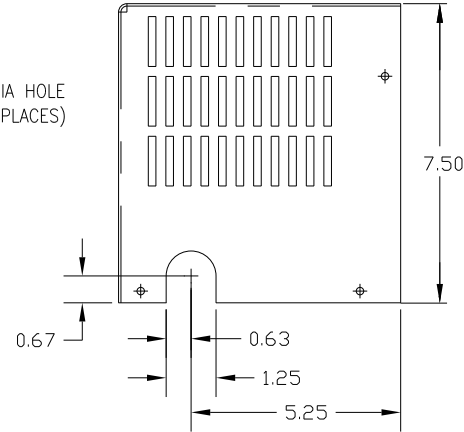
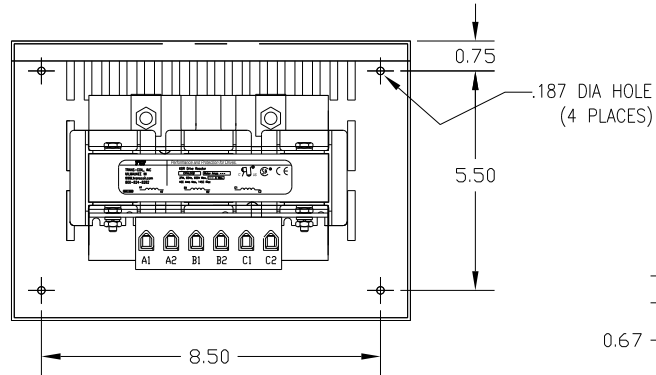
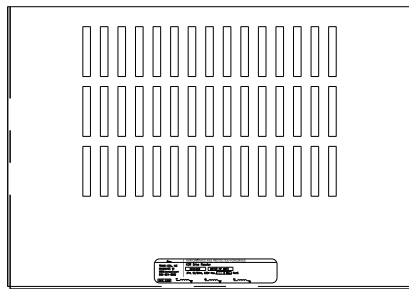
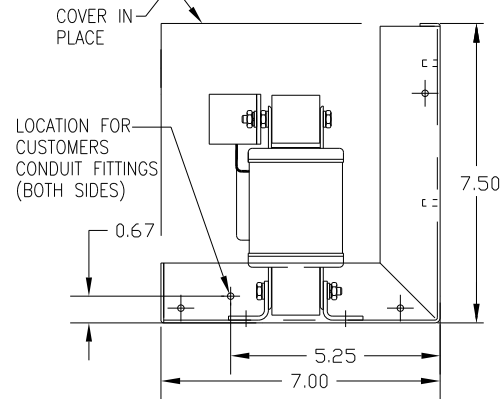
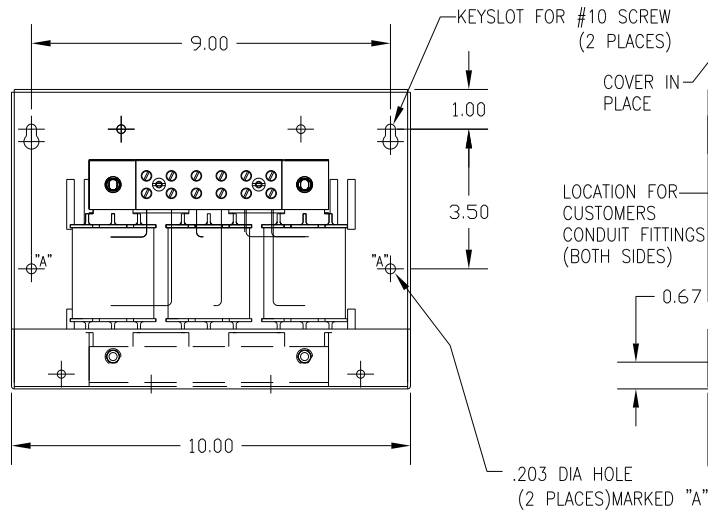
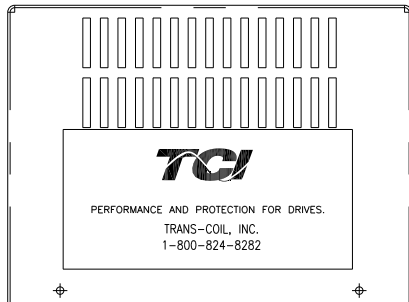

CUSTOMER IS RESPONSIBLE FOR INSTALLATION TO MEET ALL NATIONAL AND LOCAL ELECTRICAL CODES.

TOLERANCES (EXCEPT AS NOTED):				 7878 N. 86th STREET MILWAUKEE, WI 53224	
DECIMAL				KDR DRIVE REACTOR, ENCLOSED 600V LOW Z, FRAME C	
	.XX ± .03				
	.XXX ± .01				
FRACTIONAL				DRN BY	DATE
	± 1/32			DSW	2/27/2012
ANGULAR				SCALE	APRVD:
	± 1/2°				
NO	REVISION	DATE	BY	DWG. NO. B KDR43LC2DG SHT. 1 of 1	