

CATALOG NO	VOLTAGE	NEC MOTOR HP	NEC MOTOR CURRENT	WATTS LOSS	APPROX. WEIGHT-LBS	TORQUE (LB-IN)
KDRA36PDR	575	10	11	NOTE 1	5	10

NOTE 1: WATTS LOSS WILL VARY DUE TO FUNDAMENTAL FREQUENCY, CARRIER FREQUENCY AND OTHER SYSTEM CHARACTERISTICS.

KDR DRIVE REACTORS COMPLY WITH THE THERMAL AND ALTITUDE STANDARDS SET FORTH BY NEMA ST20-1992..

BRACKET ALLOWS FOR QUICK INSTALLATION OF REACTOR ON DIN RAIL.

TCI Performance and Protection for Drives.

TRANS-COIL, INC
MILWAUKEE, WI
WWW.transcoil.com
800-824-8282

KLR Series Line Reactor
CATALOG#
3PH, 60Hz, 600V Max, --- Amps
40C Amb Max, 115C Rise

KDR DRIVE REACTORS COMPLY WITH THE THERMAL AND ALTITUDE STANDARDS SET FORTH BY NEMA ST20-1992..

NOTE: CUSTOMER CAN CHANGE MOUNTED REACTOR, FROM VERTICAL TO HORIZONTAL ON DIN BRACKET.

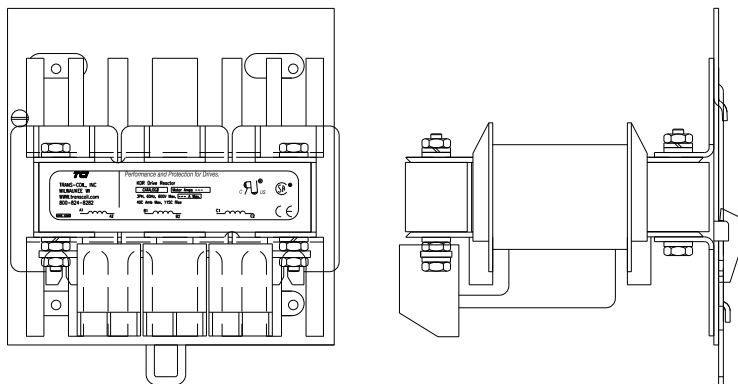

NOTE: A1, A2, B1, B2, C1, C2, ON TERMINAL BLOCK FOR REFERENCE ONLY.

BLOCK WIRE RANGE FOR REACTOR AND TIGHTENING TORQUE.	#12-#18 AWG 10 LB-IN
---	-------------------------

TCI'S DIN RAIL MOUNTED REACTORS FIT STANDARD 35mm DIN RAIL. TCI'S MINIMUM RECOMMENDATION IS TO USE: HIGH PROFILE STANDARD 35mm STEEL RAIL OR HEAVY DUTY STANDARD 35mm STEEL RAIL.

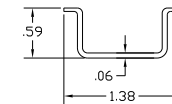

STANDARD STEEL HIGH PROFILE DIN RAIL.

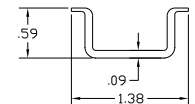

HEAVY DUTY STEEL DIN RAIL.

TCI RECOMMENDS TAKING PRECAUTIONS WHEN SHIPPING MOUNTED REACTORS.

				TOLERANCES (EXCEPT AS NOTED)		7878 N. 86th STREET MILWAUKEE, WI 53224	
				DECIMAL			
				.XX ± .03		KDR 575V DIN RAIL FRAME A	
				.XXX ± .01			
				FRACTIONAL		DRN BY DSW DATE 11/29/2011 DWG NO. KDRA36PDRDG	
				± 1/32		SCALE NONE	
				ANGULAR		APPRV: C SHT. 1 OF 1	
				± 1/2°			
NO	REVISION	DATE	BY				