

GASKET MATERIAL
PART# 32182-3

PART# 32542
APPROXIMATE WEIGHT 0.534 LBS

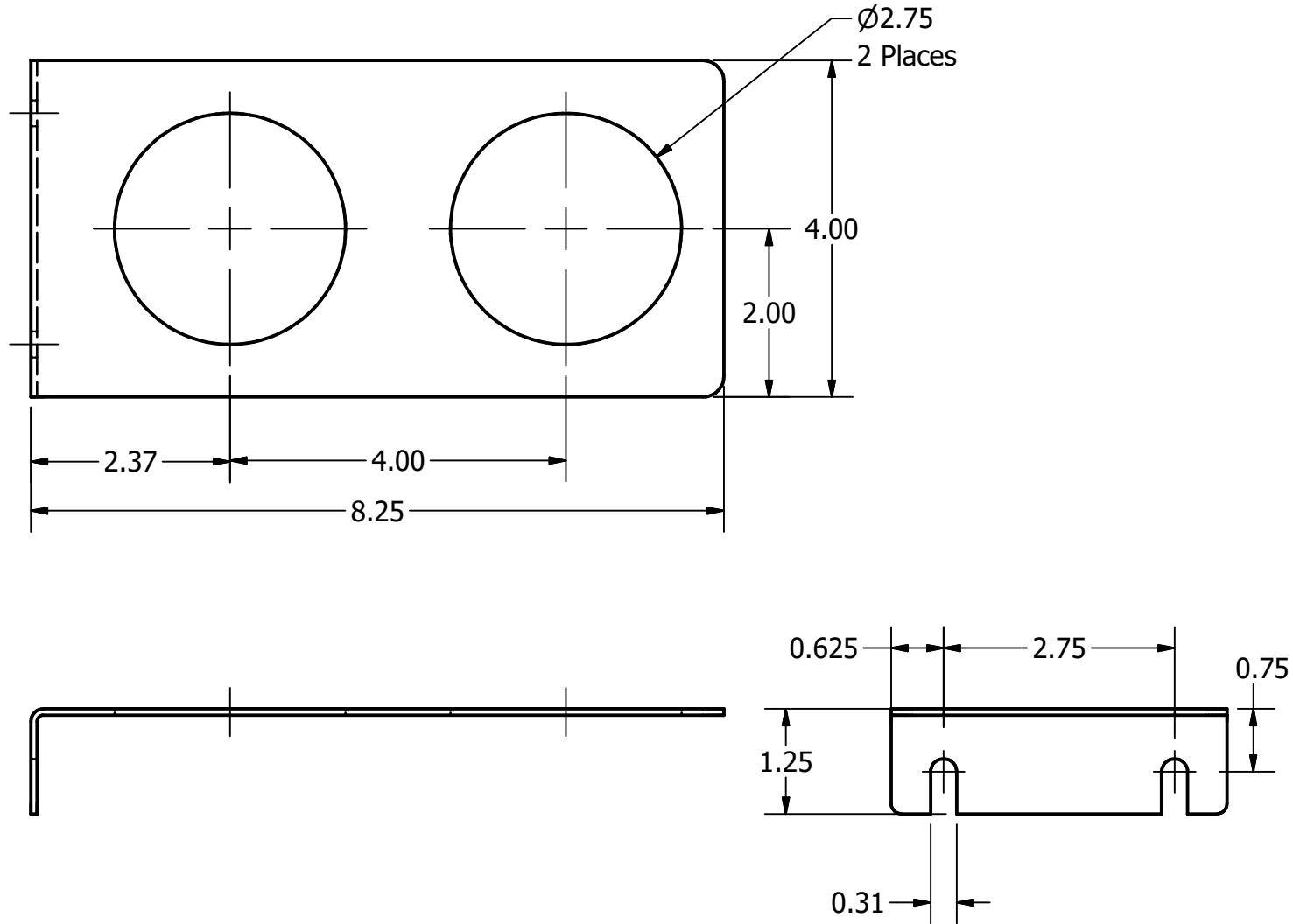

PART# 16690
APPROXIMATE WEIGHT 0.075 LBS

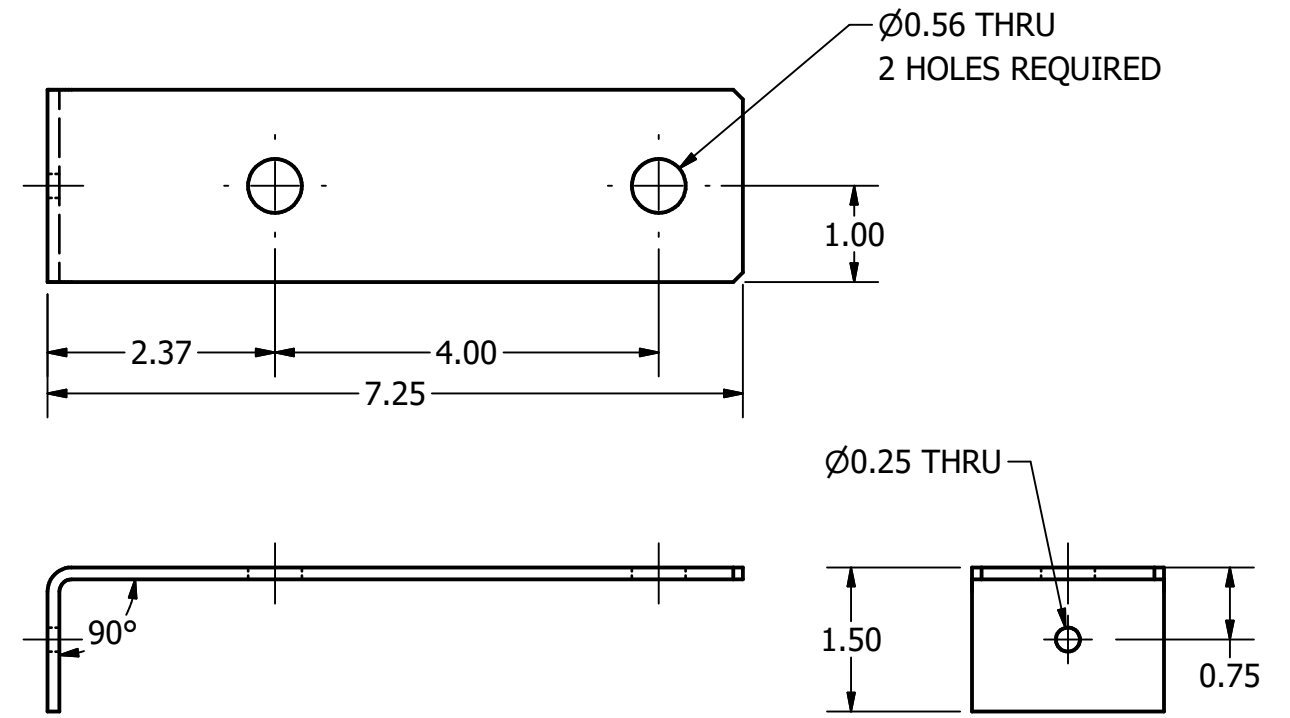

HOLE TOLERANCE $\pm .005$
Material(s) shall be RoHS compliant

THE INFORMATION AND DESIGNS CONTAINED IN THIS DRAWING ARE CONFIDENTIAL AND THE PROPRIETARY PROPERTY OF ALLIED MOTION TECHNOLOGIES INC. AND ITS SUBSIDIARIES. NEITHER THIS DESIGN NOR ANY INFORMATION CONTAINED IN THIS DRAWING MAY BE REPRODUCED OR DISCLOSED TO OTHERS WITHOUT THE EXPRESS WRITTEN CONSENT OF ALLIED MOTION TECHNOLOGIES INC. AND ITS SUBSIDIARIES.

NO	REVISION	DATE	BY
A	As Designed	8/29/2022	DSW

TOLERANCES (EXCEPT AS NOTED)
DECIMAL
.XX $\pm .03$
.XXX $\pm .010$
FRACTIONAL
$\pm 1/32$
ANGULAR
$\pm 1^\circ$

TCI
An Allied Motion Company

W132N10611 Grant Drive
Germantown, WI 53022
© 2021 TCI, LLC

2 Hole Bracket kit, (2) 2.75" Dia
4." Wide, 2.75" Mounting.

DRN. BY: DSW DATE: 8/29/2022
SCALE: 1:2 APRVD: KCAPBKT2E
SIZE: B SHT.1 OF 1