

Unit Specifications						
HP	kVar	Harmonic	Volt	HZ.	Maximum Amps (A)	Phase
600	90	5TH	480	60	720	3

Note: For Torque Information See IOM Manual

Customer Connections:  
L1, L2, L3, T1, T2, T3, and Ground Lug.  
Wire Range- Three, 600MCM-2AWG

HGL Part Number	Schematic Drawing #	Approx Weight (LBS)
HGL0600AW3S0000	30586-1S	1275
HGL0600AW3C0000	30586-1C	1295
HGL0600AW3S1000	30586-PQ1	1278
HGL0600AW3C1000	30586-PQ	1298

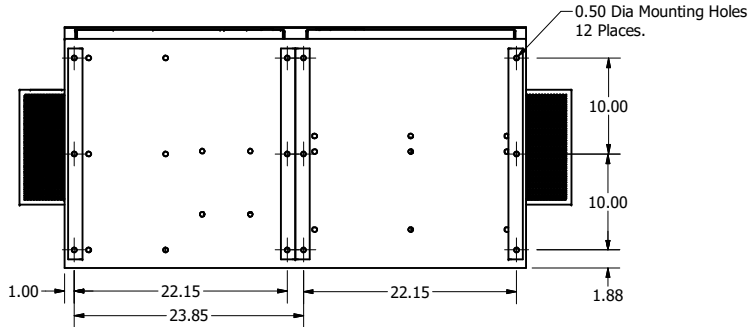
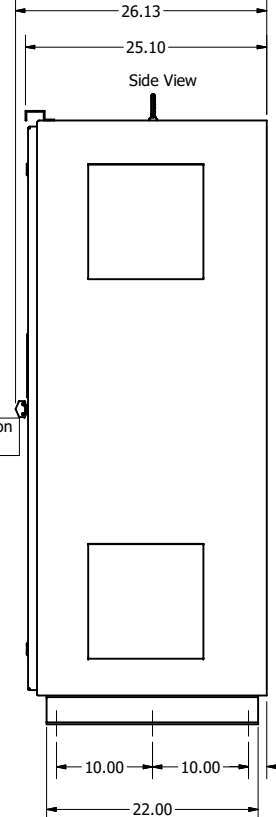
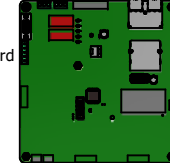
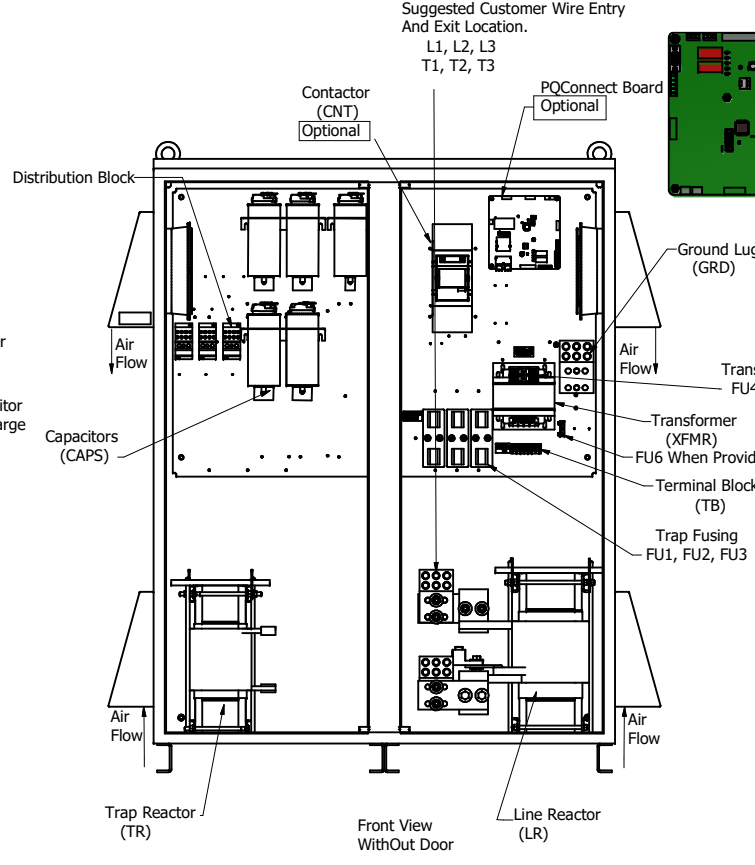
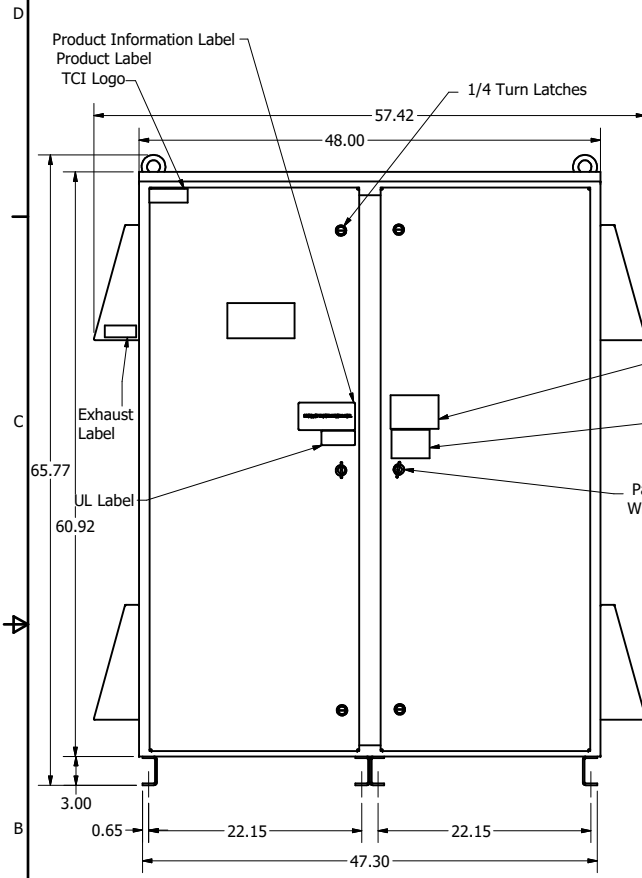

HGL0600AW3-----				
Components	S0000	C0000	S1000	C1000
Line Reactor (LR)	x	x	X	X
Trap Reactor (TR)	x	x	X	X
Capacitor (Cap)	x	x	X	X
Trap Fusing, FU1, FU2, FU3	x	x	X	X
Contactor (CNT)		x		X
Transformer (XFMR)	x	x	X	X
XFMR Fusing, FU4, FU5	x	x	X	X
PQConnect Board			X	X

Customer Is Responsible For Installation to Meet All National And Local Electrical Codes.  
NOTE: USE ONLY HUBS OR FITTINGS THAT COMPLY WITH UL514B FOR TYPE 3R ENCLOSURES

Material(s) Shall be RoHS Compliant

THE INFORMATION AND DESIGNS CONTAINED IN THIS DRAWING ARE CONFIDENTIAL AND THE PROPRIETARY PROPERTY OF ALLIED MOTION TECHNOLOGIES INC. AND ITS SUBSIDIARIES. NEITHER THIS DESIGN NOR ANY INFORMATION CONTAINED IN THIS DRAWING MAY BE REPRODUCED OR DISCLOSED TO OTHERS WITHOUT THE EXPRESS WRITTEN CONSENT OF ALLIED MOTION TECHNOLOGIES INC. AND ITS SUBSIDIARIES.				TOLERANCES (EXCEPT AS NOTED) DECIMAL .XX ±.25 .XXX ±.10	
C	5653, GE to ABB CHG	1/10/2022	DSW	FRACTIONAL ± 1/16	<p>W132N10611 (Rev 11/16) Germano, WI 53012 © 2022 TCI, LLC An Official Motion Control Company HarmonicGuard Low Capacitance HGL, 600HP, 480/3/60, Type 3R</p>
B	Add PQconnect	2/19/19	DSW	ANGULAR ± 1°	
NO	REVISION	DATE	BY		

DRN BY: DSW DATE: 10/12/17 FILE: 107278DG  
SCALE: 1/8 DRAWN BY: CJC SHEET 1 OF 1