

SEE DWG# 26972-2 FOR SCHEMATIC  
 CUSTOMER IS RESPONSIBLE FOR INSTALLATION  
 TO MEET ALL NATIONAL AND LOCAL ELECTRICAL CODES.  
 NOTE: USE ONLY HUBS OR FITTINGS THAT COMPLY  
 WITH UL514B FOR TYPE 3R ENCLOSURES.

UNIT SPECIFICATIONS:					
KVAR	HARMONIC	VOLT	HZ	PHASE	HP
180	5TH	600	60	3	600
ENCLOSURE		TYPE 3R- COLOR, WHITE			
APPROX.WT. LBS		1176			

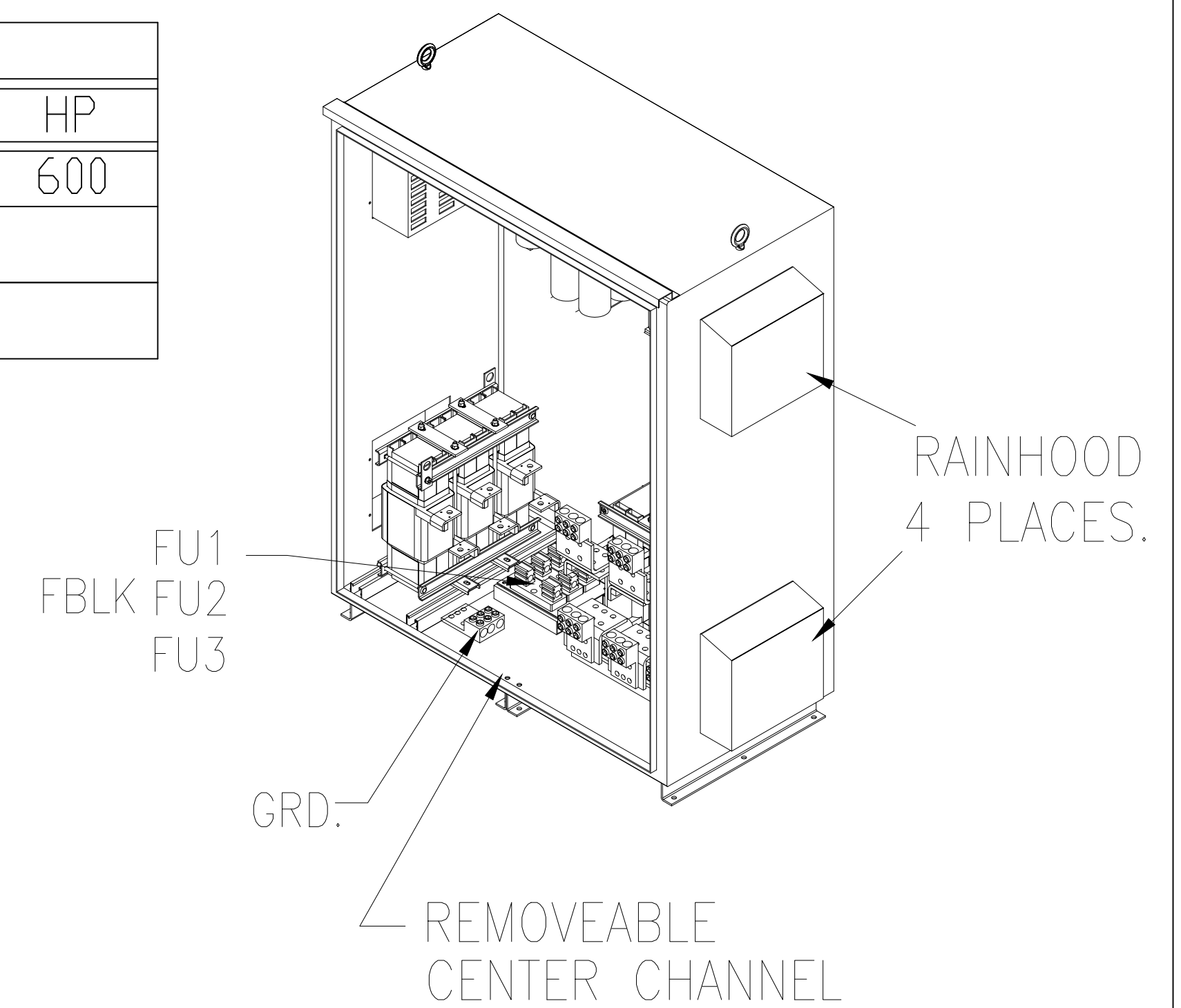
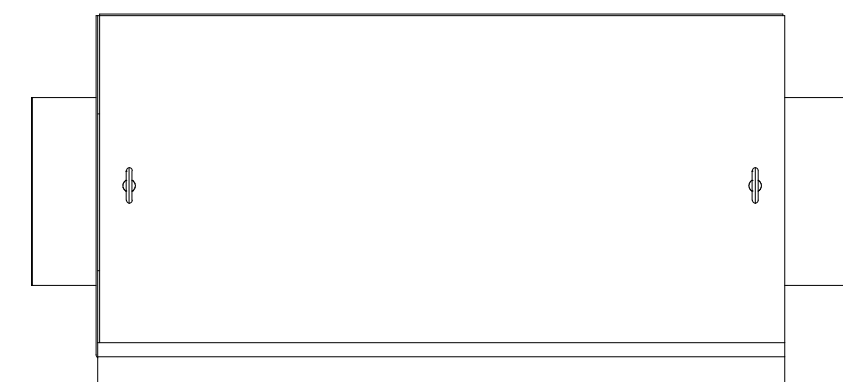
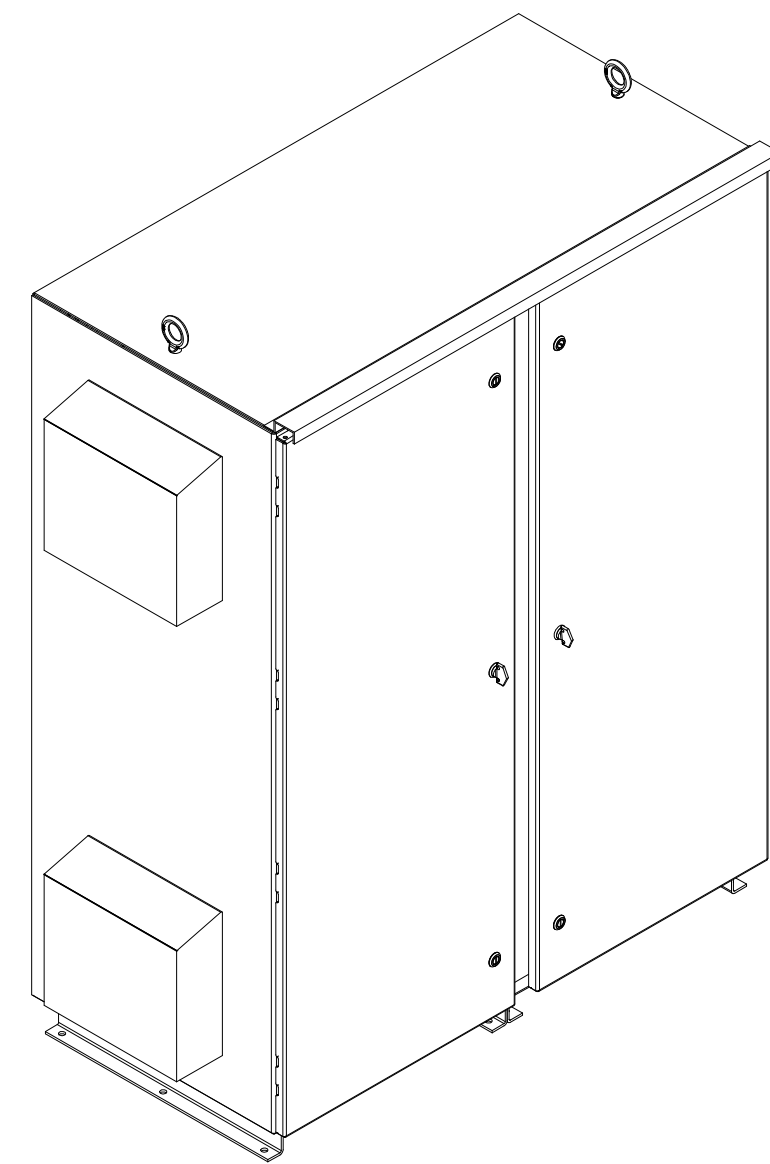

INSIDE DOOR

SIDE VIEW

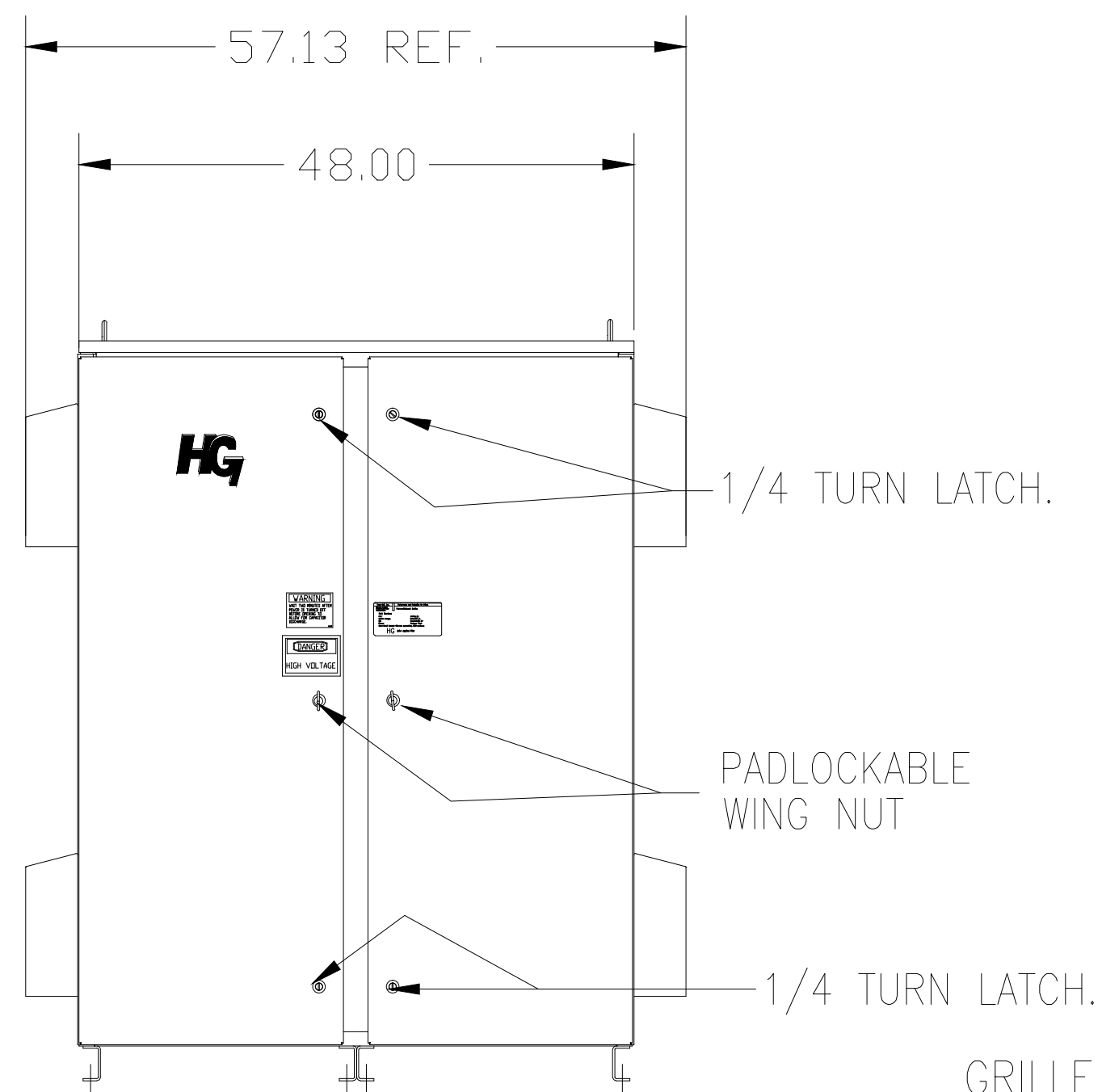
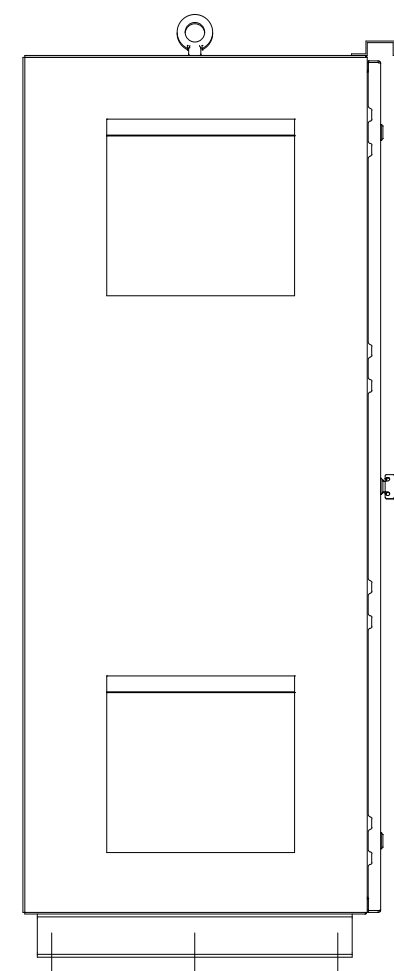
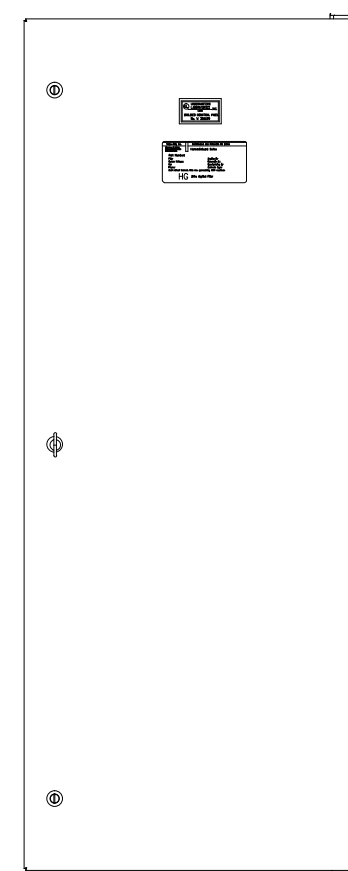

FRONT VIEW WITH DOORS.

FRONT VIEW WITHOUT DOORS

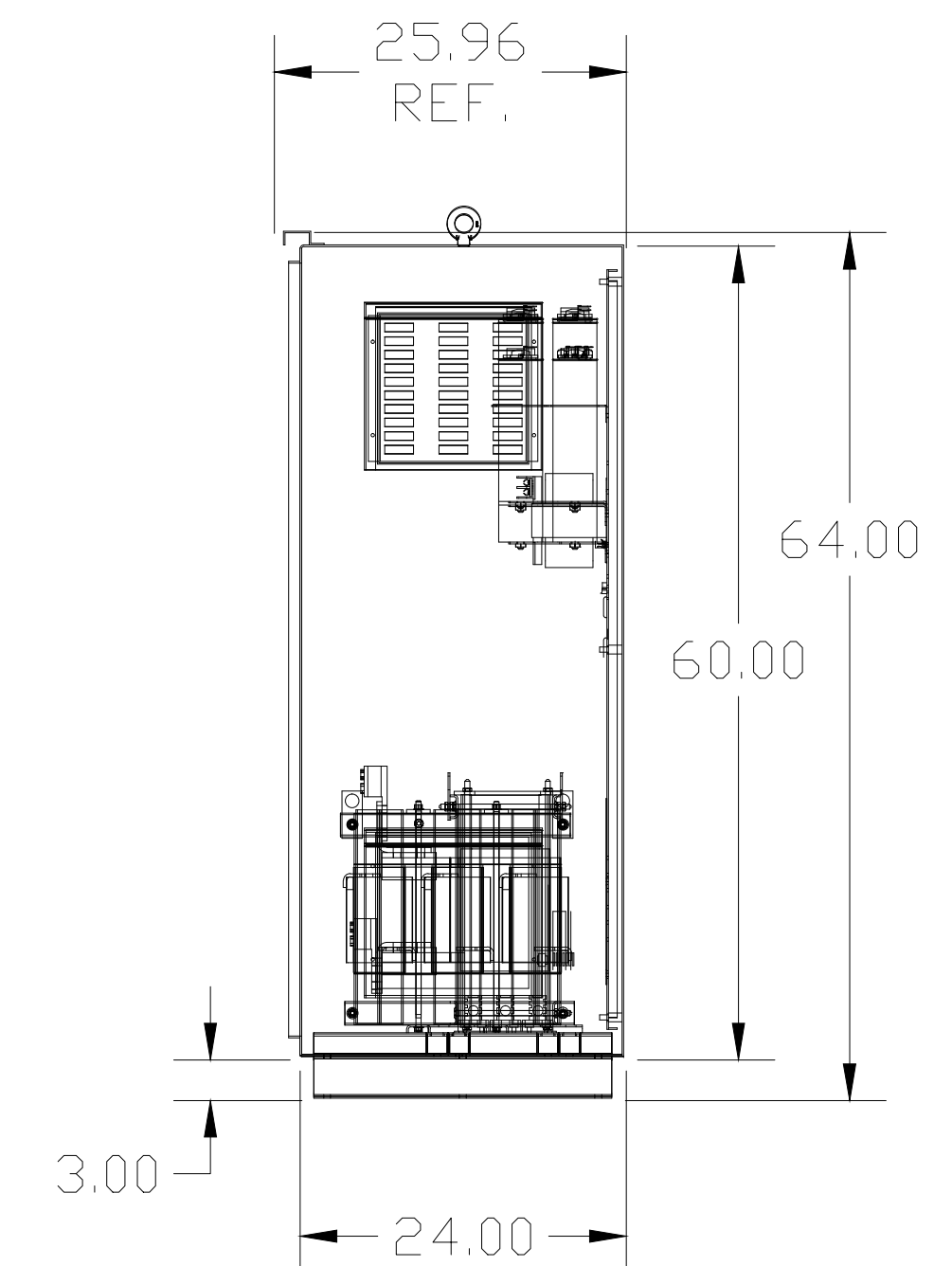
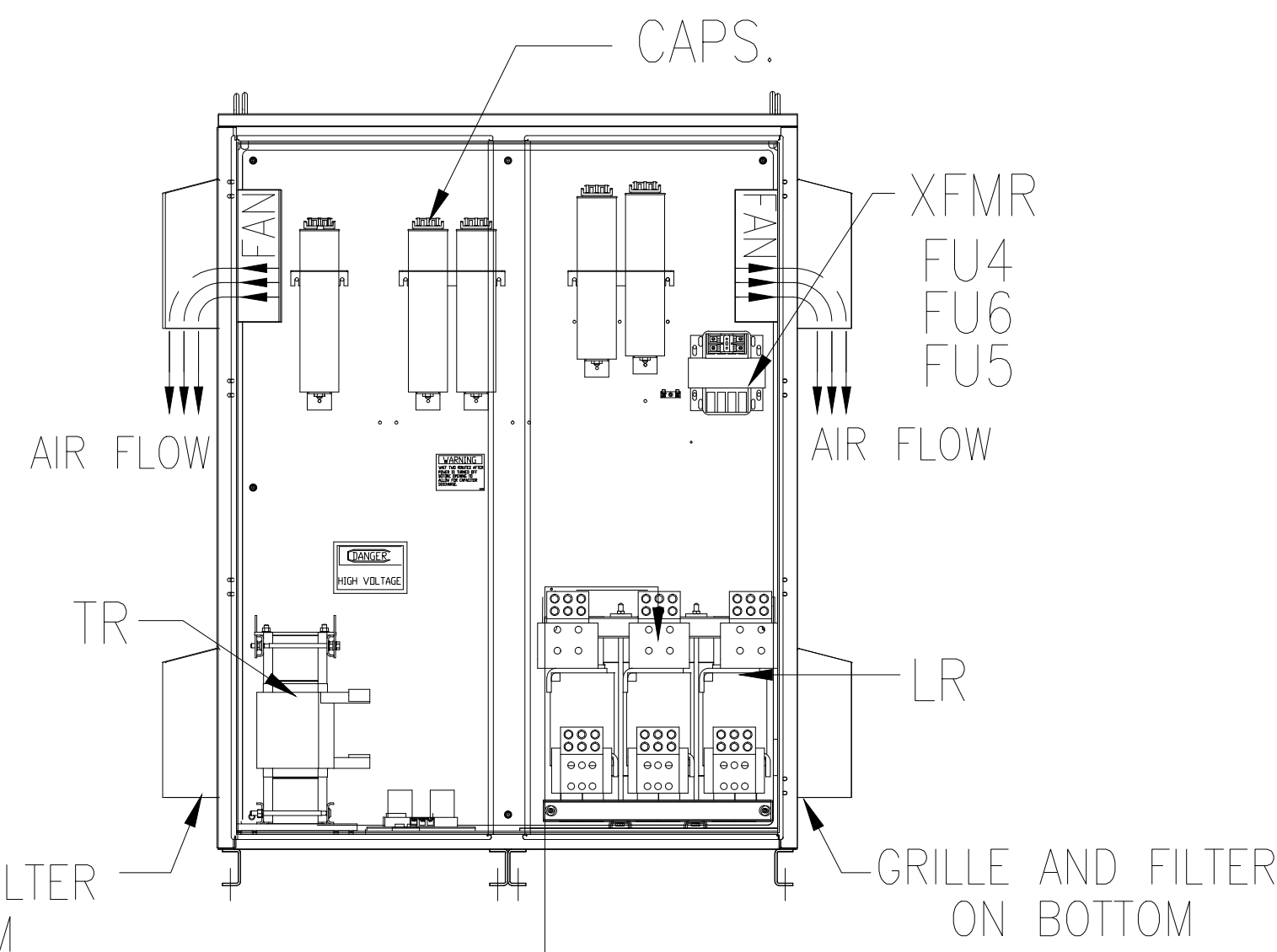

SIDE VIEW

GROUND LUG: .50 DIA HOLES 12 PLACES.  
 WIRE RANGE-TWO 600MCM-2  
 TIGHTENING TORQUE 500 IN-LB.

L1 L2 L3 T1 T2 T3  
 SUGGESTED CUSTOMER WIRE ENTRY AND EXIT LOCATION

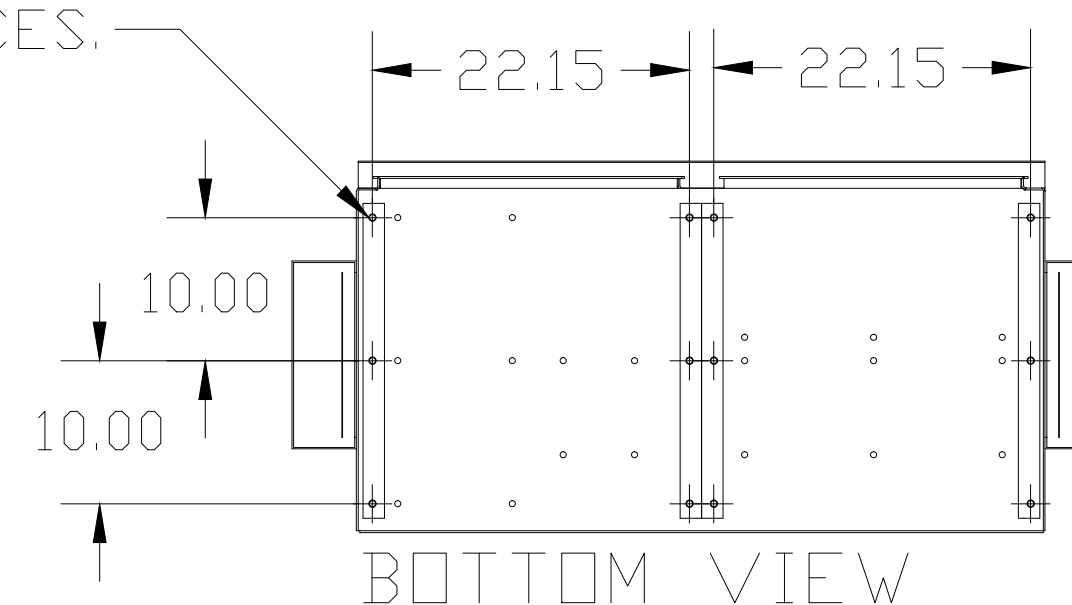

BOTTOM VIEW

CUSTOMER INPUT/OUTPUT CONNECTIONS:  
 WIRE RANGE-TWO 600MCM-2  
 TIGHTENING TORQUE 500 IN-LB.

SYMBOL	TCI PART NUMBER
LR	KDRY42T
TR	KTR180C65HG
(20 KVAR) 9 PLACES.	KCAP20C6B
XFMR.	24389
Fu1;2;3	13232
Fu4,6	24390
Fu5	23977

TCI, LLC CLAIMS PROPRIETARY RIGHTS IN THE MATERIAL HEREIN DISCLOSED. IT IS SUPPLIED WITHOUT PREJUDICE TO ANY PATENT RIGHTS OF TCI AND MAY NOT BE REPRODUCED OR USED TO MANUFACTURE ANYTHING SHOWN THEREIN WITHOUT WRITTEN PERMISSION FROM TCI.				TOLERANCES (EXCEPT AS NOTED) DECIMAL XX ±.12 XXX ±.06 FRACTIONAL ± 1/32 ANGULAR ± 1/2°		w132 N10611 Grant Drive Germantown, WI 53022	
				HG600CW03ST, 600HP 600/3/60 UL TYPE 3R		DRN BY DSW DATE 2/26/09 DWG NO 103650DG	
NO	REVISION	DATE	BY	SCALE TO FIT	SIZE D	SHT.1 OF 1	