

CUSTOMER IS RESPONSIBLE FOR INSTALLATION TO MEET ALL NATIONAL AND LOCAL ELECTRICAL CODES.

NOTE: USE ONLY HUBS OR FITTINGS THAT COMPLY WITH UL514B FOR TYPE 3R ENCLOSURES.

SEE DWG# 26972-2 FOR SCHEMATIC

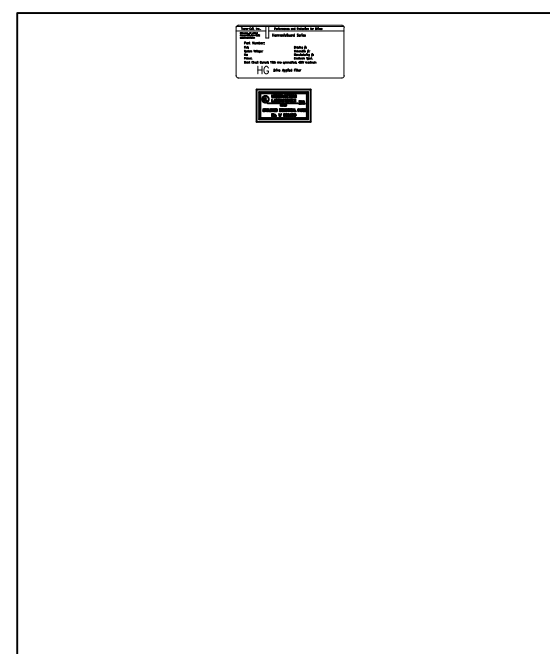
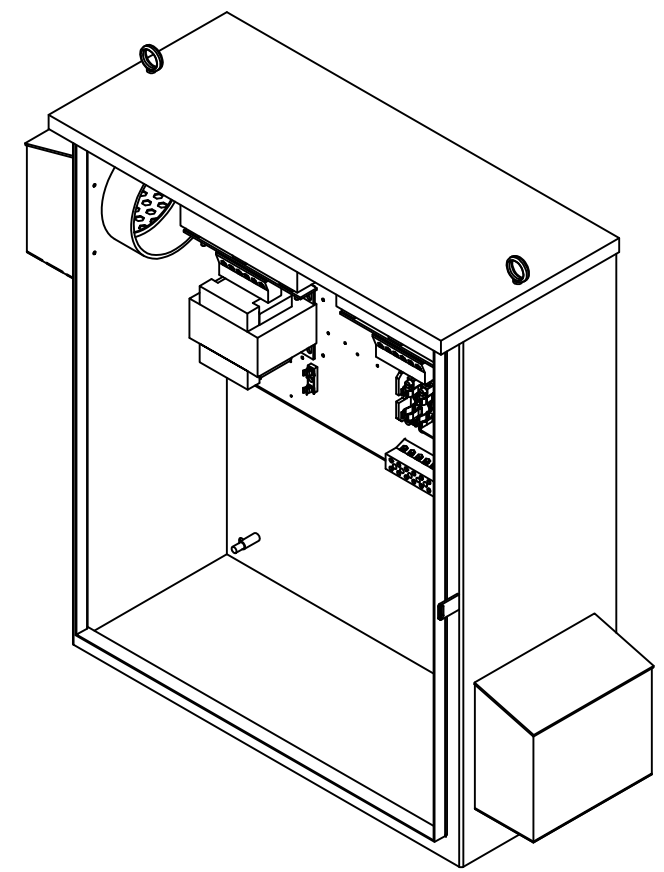
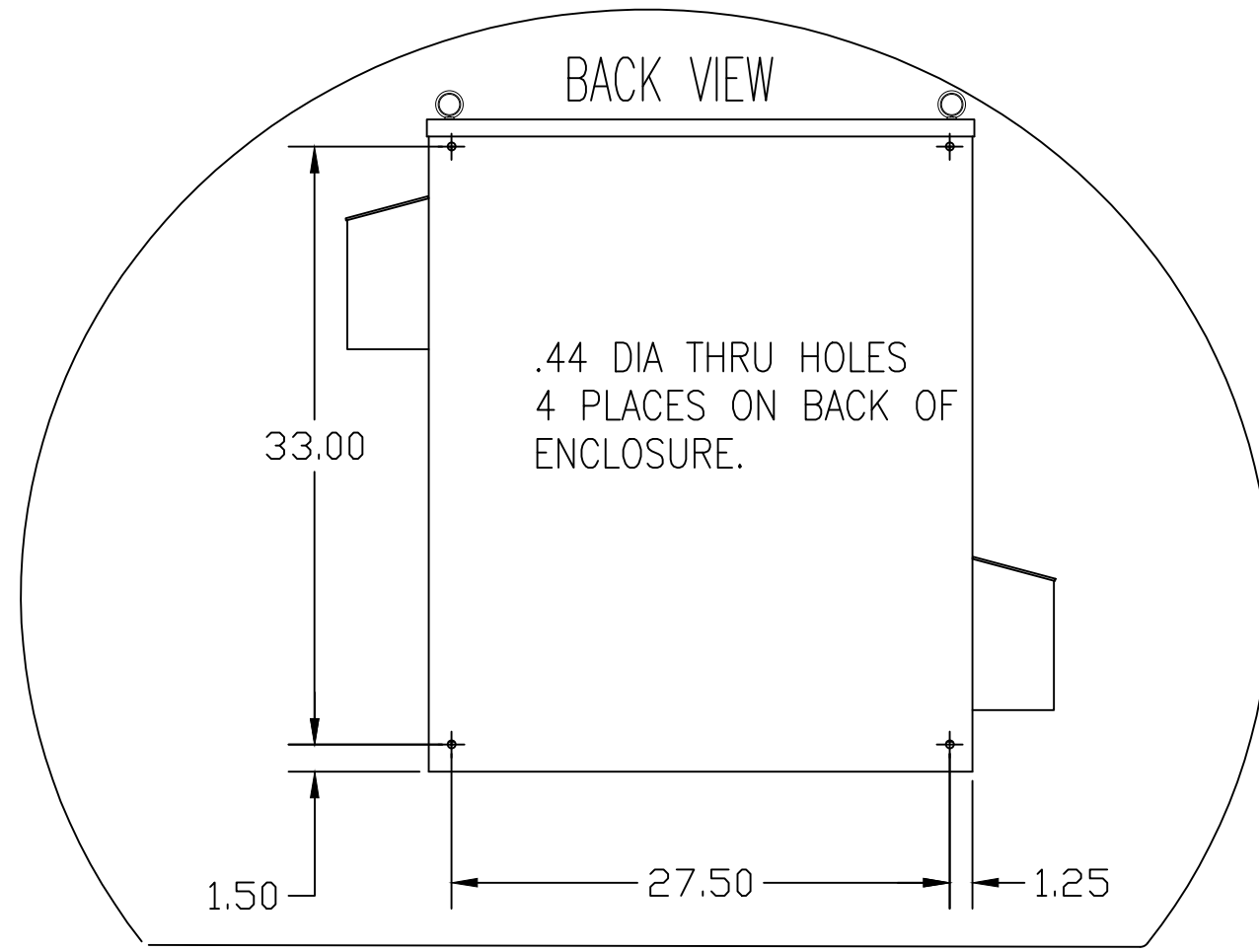
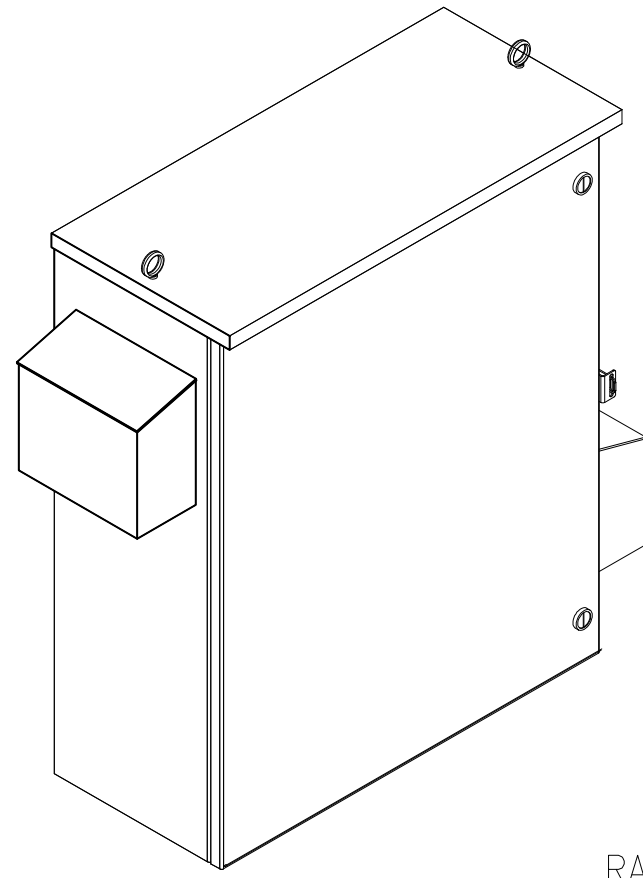

SIDE VIEW

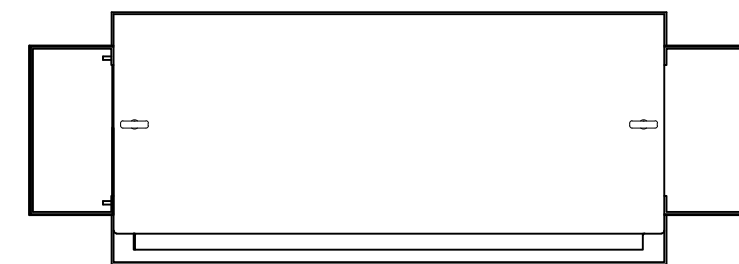
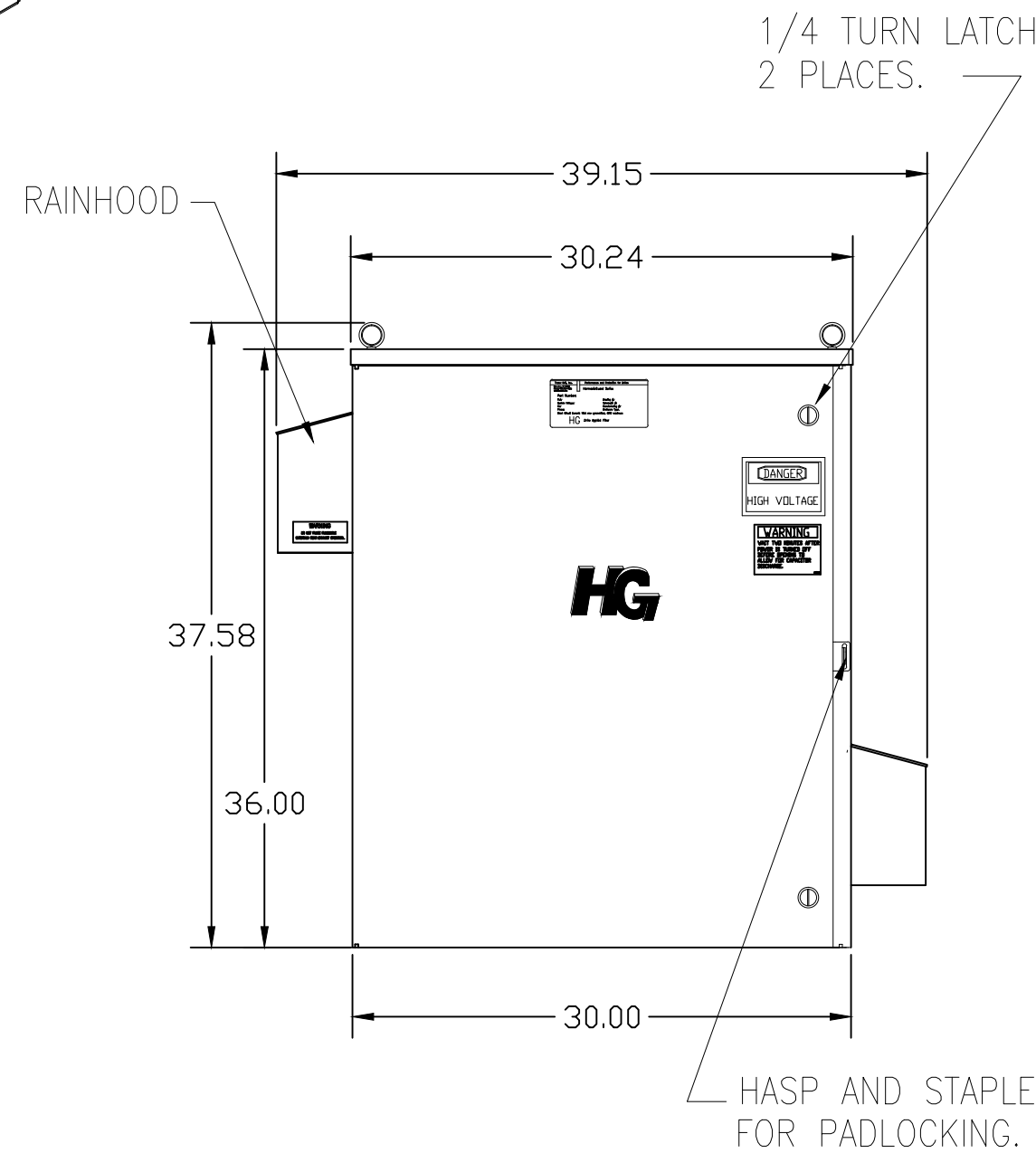
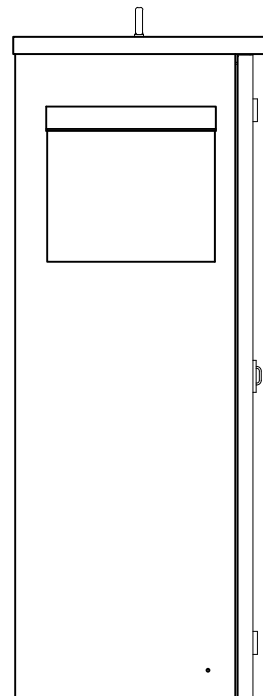

SIDE VIEW

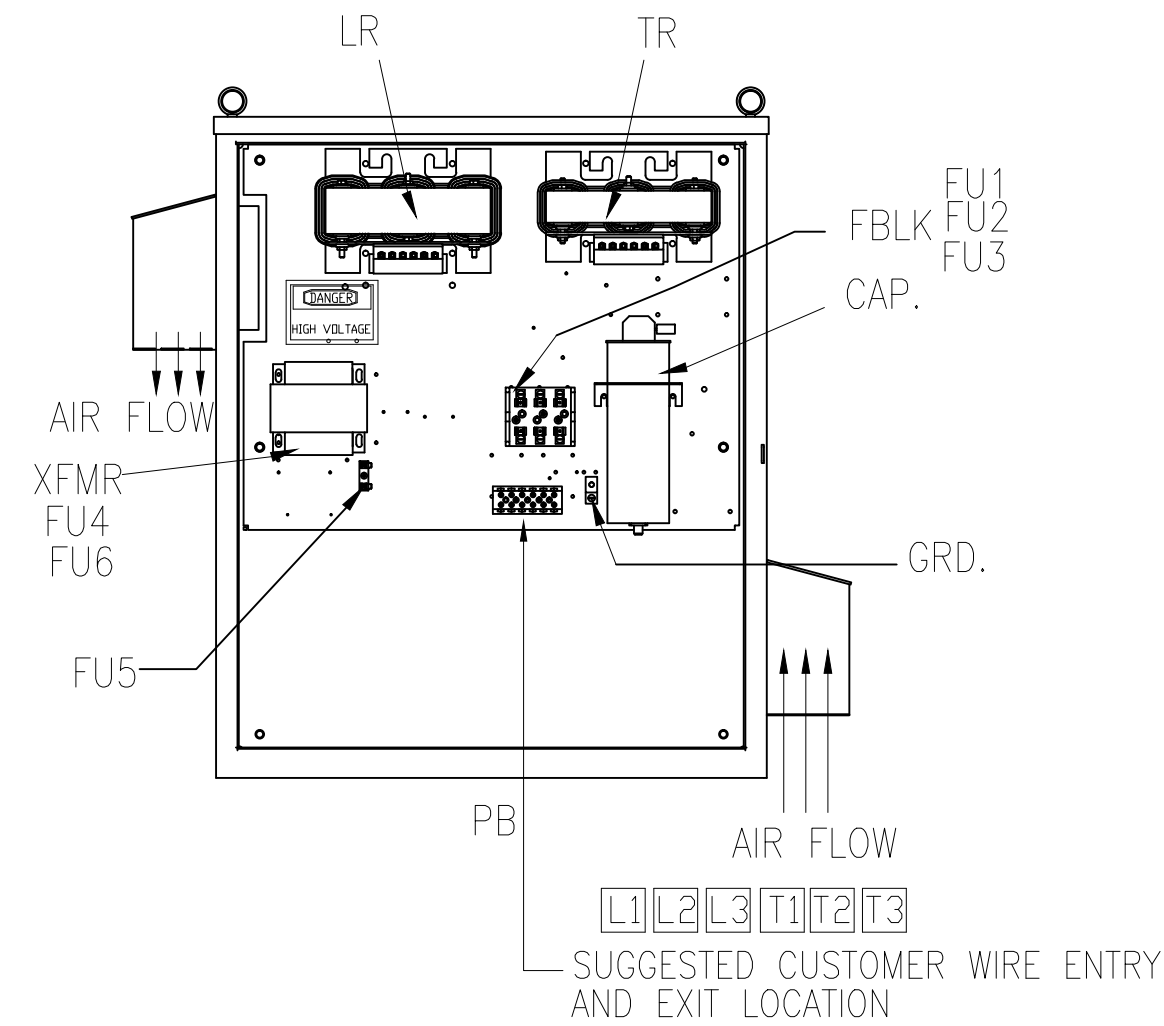
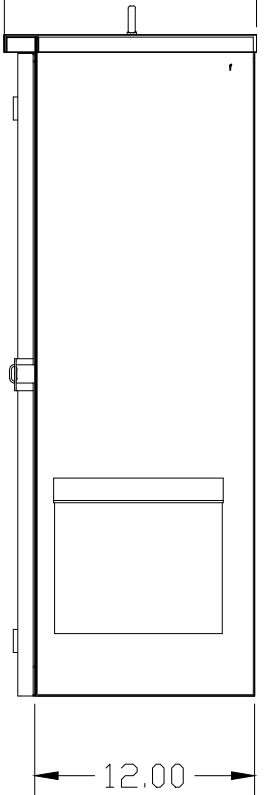

INSIDE DOOR

UNIT SPECIFICATIONS:					
KVAR	HARMONIC	VOLT	HZ	PHASE	HP
15	5TH	600	60	3	50
ENCLOSURE		UL TYPE 3R			
COLOR		WHITE			
APPROX.WT. LBS.		249			

HG50CW03ST	
COMPONENTS	
LINE REACTOR LR	X
TRAP REACTOR TR	X
CAPACITOR CAP	X
TRAP FUSING FU1,2,3	X
TRANSFORMER	X
TRANSFORMER FUSING FU4,6	X
TRANSFORMER FUSING FU5	X

PB-POWER INPUT BLOCK:  
WIRE RANGE-#18 TO #4 AWG.  
TIGHTENING TORQUE 20 IN-LB.

GROUND LUG:  
WIRE RANGE-1/0 TO #14 AWG.  
1/0 AWG thru 2 AWG 50 IN-LBS. MAX.  
4 AWG thru 6 AWG 45 IN-LBS. MAX.  
8 AWG 40 IN-LBS MAX.  
10 AWG thru 14 AWG 35 IN-LBS. MAX.

TCI, LLC CLAIMS PROPRIETARY RIGHTS IN THE MATERIAL HEREIN DISCLOSED. IT IS SUPPLIED WITHOUT PREJUDICE TO ANY PATENT RIGHTS OF TCI AND MAY NOT BE REPRODUCED OR USED TO MANUFACTURE ANYTHING SHOWN THEREIN WITHOUT WRITTEN PERMISSION FROM TCI.				TOLERANCES (EXCEPT AS NOTED)	W132 N10611 Grant Drive Germantown, WI 53022 <b>HG50CW03ST, 50HP</b> <b>600/3/60 UL TYPE 3R</b>
				DECIMAL	
				.XX ±.12	
				.XXX±.03	
	B 3033 UPDATE LAYOUT	2/18/14	DSW	FRACTIONAL ± 1/32	DRN. BY DSW DATE 2/24/09 DWG. NO. 103637DG SCALE TO FIT SIZE C
	A 2641 ADD EYEBOLTS	10/13/09	DSW	ANGULAR ± 1/2°	
	NO REVISION	DATE	BY		SHT. 1 OF 1