

UNIT SPECIFICATIONS:						
KW	HARMONIC	VOLT	HZ	PHASE	FLA	
37	5TH	400	50	3	75	
ENCLOSURE		WHITE OPEN PANEL				
APPROX.WT. LBS.		130				

SYMBOL	TCI PART NUMBER
LR	KDRG32T
TR	KTR15L55HG
CAP1. (10 KVAR)	KCAP10A6B
CAP2. (15 KVAR)	KCAP15A6B
Fu1, 2, 3	22925

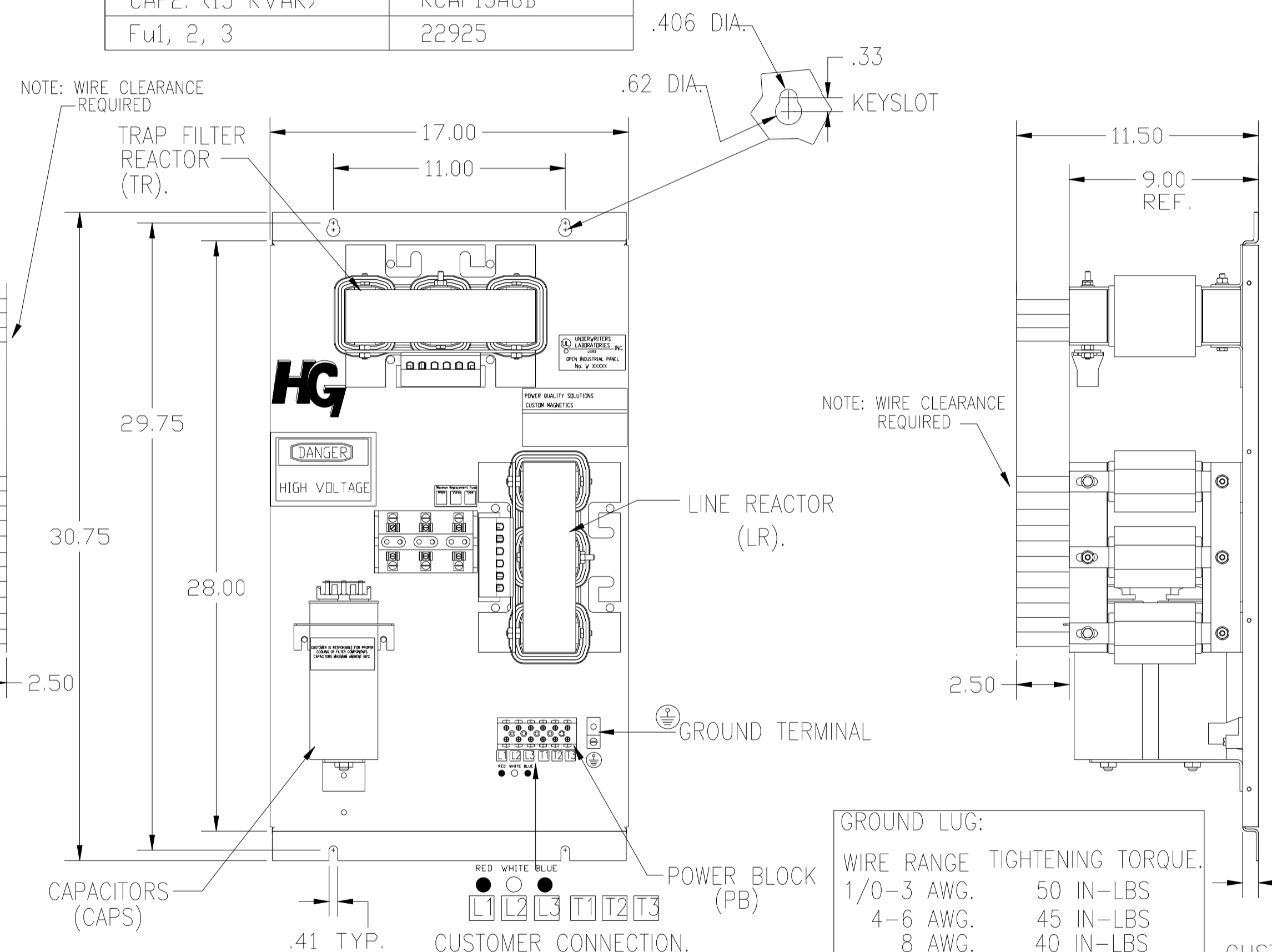
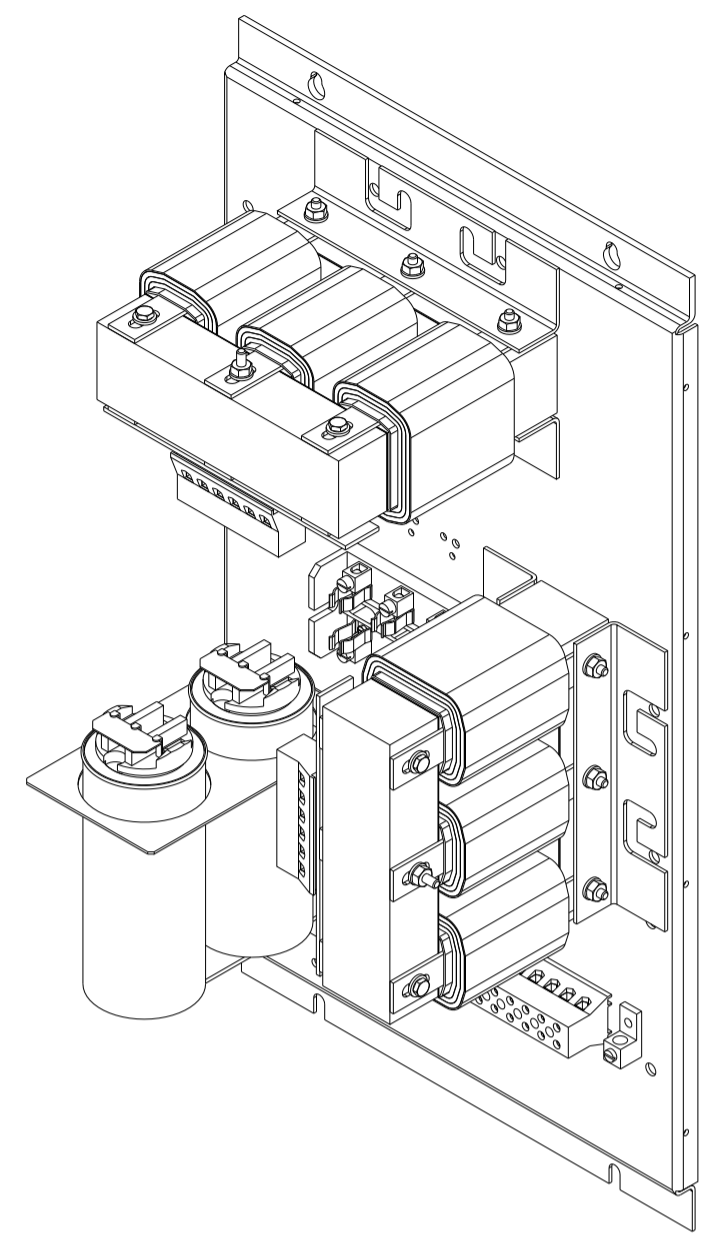
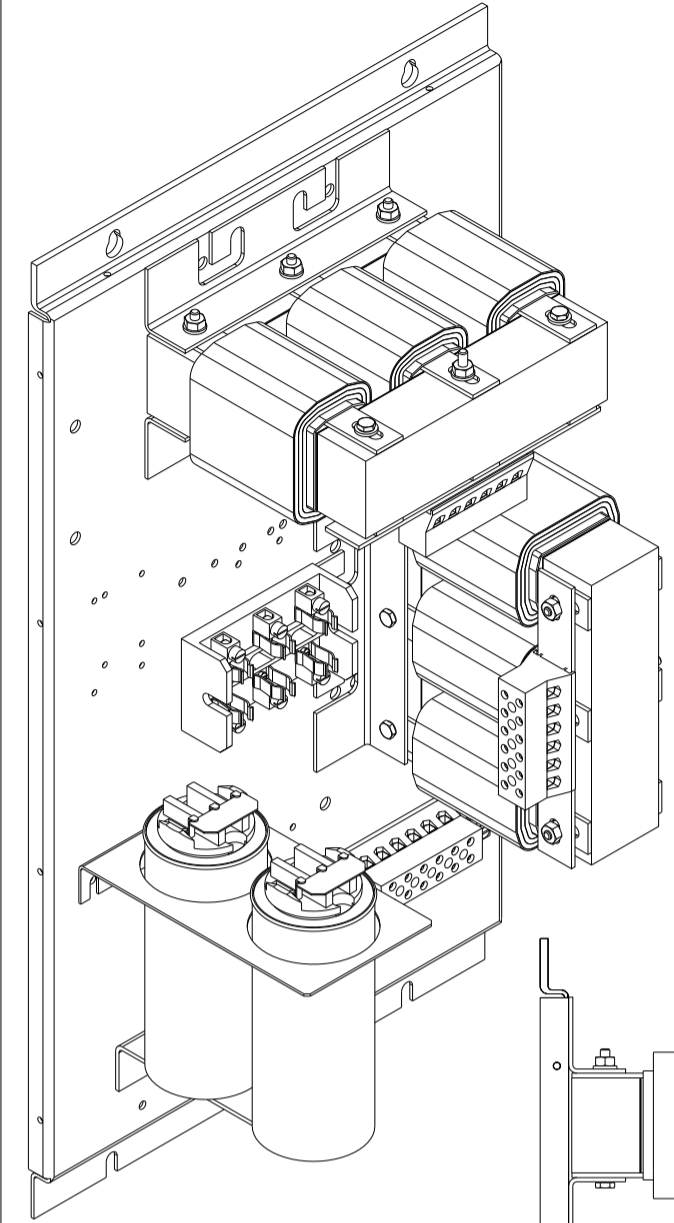

GROUND LUG:	
WIRE RANGE	TIGHTENING TORQUE.
1/0-3 AWG.	50 IN-LBS
4-6 AWG.	45 IN-LBS
8 AWG.	40 IN-LBS
10-14 AWG.	35 IN-LBS

PB-POWER INPUT BLOCK:
 1 AWG thru 4 AWG 35 IN-LBS. MAX.
 6 AWG thru 14 AWG 30 IN-LBS. MAX.
 16 AWG thru 20 AWG 25 IN-LBS MAX.
 22 AWG 20 IN-LBS MAX.

CUSTOMER IS RESPONSIBLE FOR PROPER COOLING OF FILTER COMPONENTS. CAPACITORS MAXIMUM AMBIENT 50°C.

CUSTOMER IS RESPONSIBLE FOR INSTALLATION TO MEET ALL NATIONAL AND LOCAL ELECTRICAL CODES.

SEE DRAWING# 27709 FOR SCHEMATIC

		TOLERANCES (EXCEPT AS NOTED)		 7878 N. 86th STREET MILWAUKEE, WI 53224	
		DECIMAL		HG37LW00ST, 37KW 400/3/50, OPEN.	
		.XX ± .03		DRN BY DSW DATE 11/15/2010 DWG. NO. 104499DG	
		.XXX ± .01		SCALE TO FIT APRVD. C SHT. 1 OF 1	
		FRACTIONAL ± 1/32			
A	AS BUILT	11/04/10	DSW		
NO	REVISION	DATE	BY		
		ANGULAR ± 1/2°			