

SEE 26824 FOR SCHEMATIC

CUSTOMER CONNECTIONS

L1 L2 L3 T1 T2 T3

AND GROUND LUG.

WIRE SIZE (AWG)	RATED TORQUE (IN-LBS)
2/0-3	50
4-6	45
8	40
10-14	35

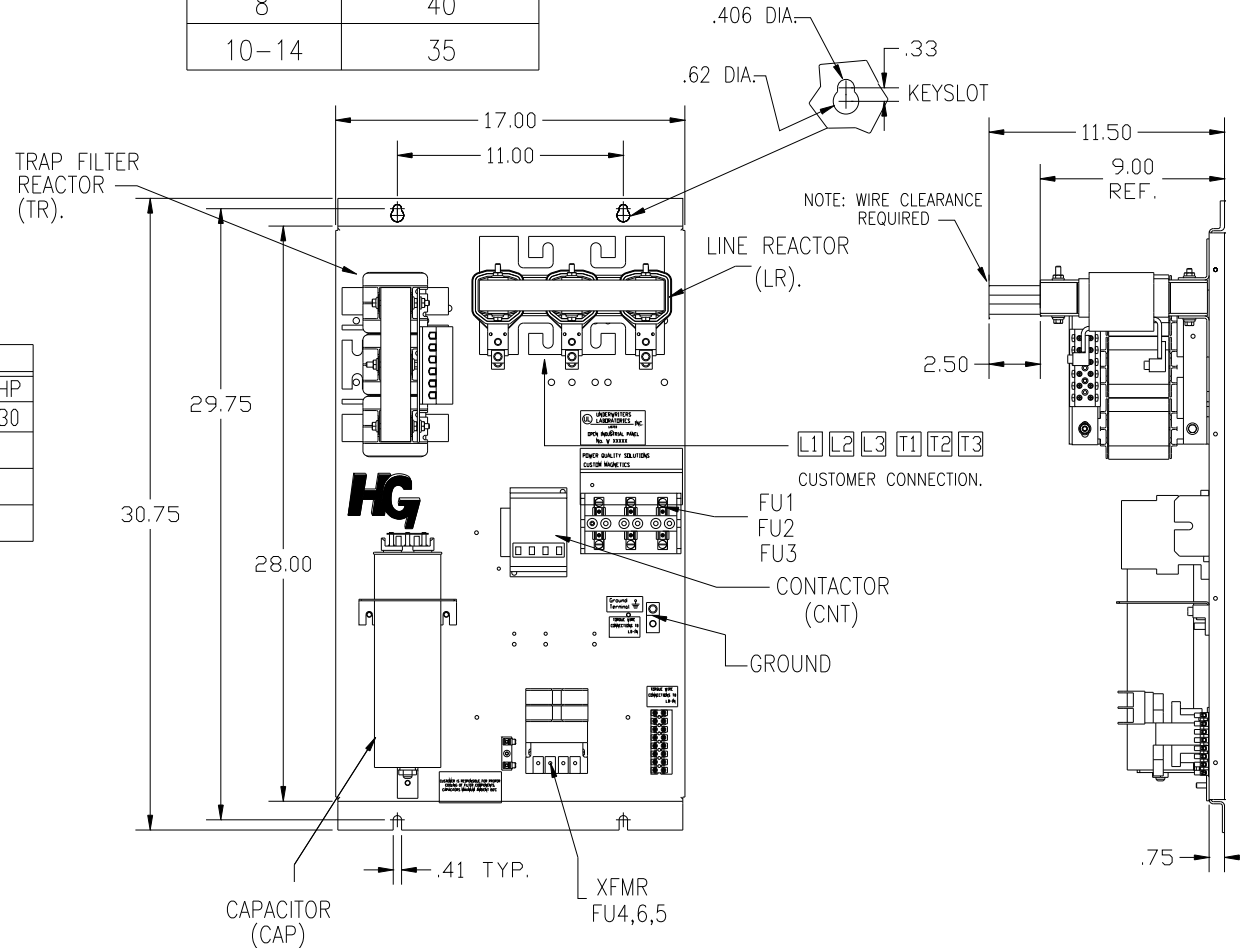
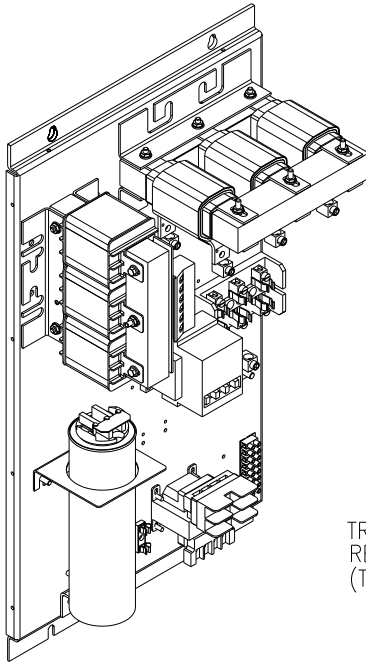

UNIT SPECIFICATIONS:						
KVAR	HARMONIC	VOLT	HZ	PHASE	HP	
10	5TH	240	60	3	30	
ENCLOSURE		WHITE OPEN PANEL				
		WITH CONTACTOR				
APPROX.WT. LBS.		105				

HG30BW00STC	
COMPONENTS	
LINE REACTOR LR	X
TRAP REACTOR TR	X
CAPACITOR CAP	X
TRAP FUSING FU1,2,3	X
XFMR	X
XFMR FU4,6	X
XFMR FU5	X
CNT	X

CUSTOMER IS RESPONSIBLE FOR PROPER COOLING OF FILTER COMPONENTS. CAPACITORS MAXIMUM AMBIENT 50°C.

CUSTOMER IS RESPONSIBLE FOR INSTALLATION TO MEET ALL NATIONAL AND LOCAL ELECTRICAL CODES.

				TOLERANCES (EXCEPT AS NOTED)		TCI 7878 N. 86th STREET MILWAUKEE, WI 53224	
				DECIMAL		HG30BW00STC, 30HP 240/3/60, OPEN, WITH CNT	
				.XX ± .03		DRN. BY DSW DATE 10/09/08 DWG. NO. 103604DG	
				.XXX ± .01		SCALE TO SCALE	
				FRACTIONAL ± 1/32		APPROVED	
3042 LUG TORQ CHG				2/21/14	BMZ	ANGULAR ± 1/2°	
NO REVISION				DATE	BY	SHT. 1 OF 1	