

Allient Part Number	Ohms x 3	Amps x 3	Watts	Approx Weight (LBS)
22944	0.69	20.22	274	4.5

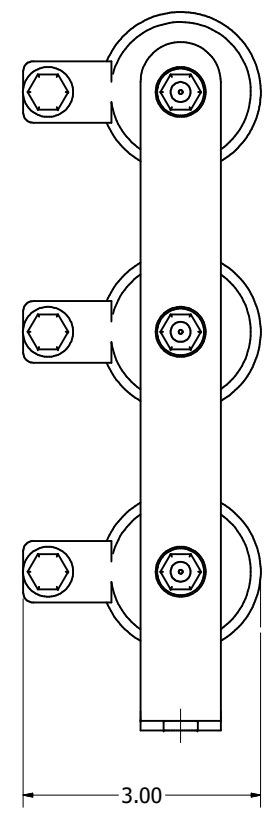
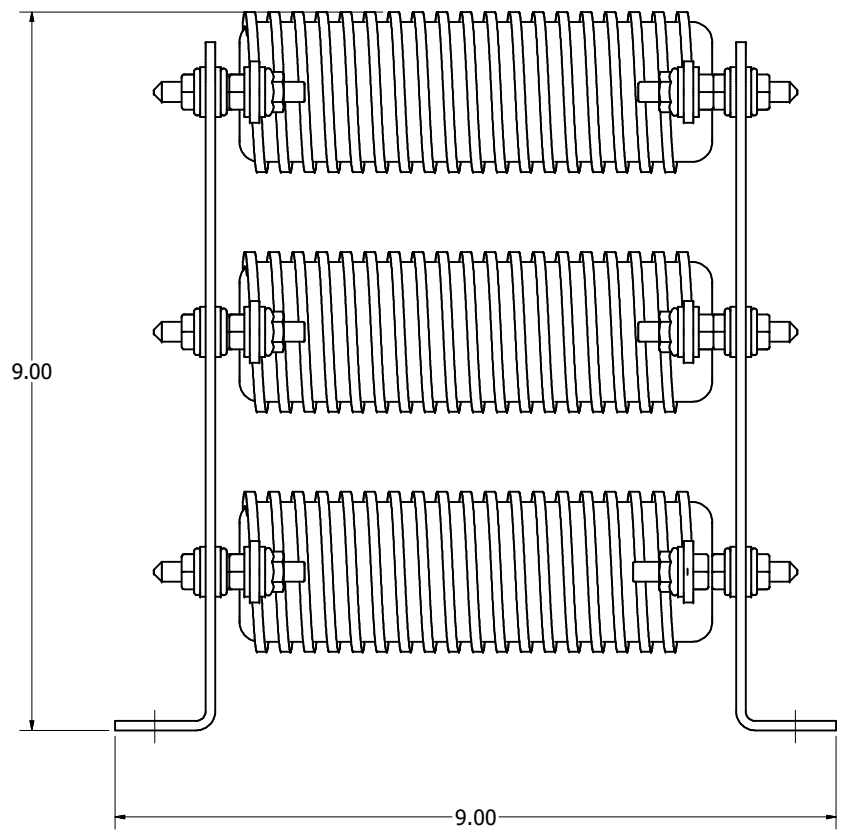
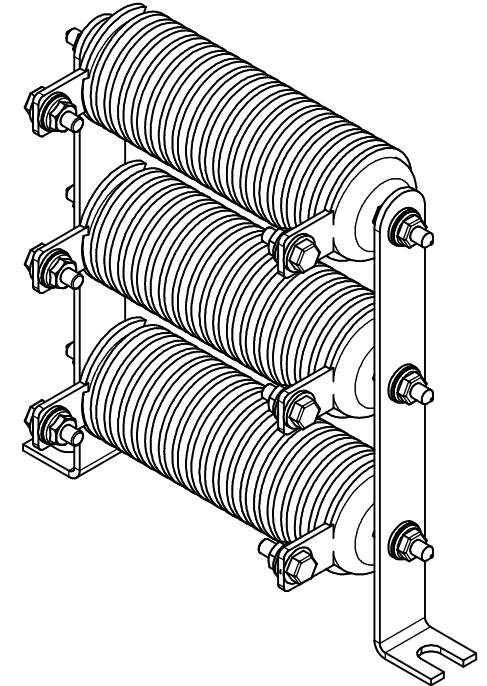
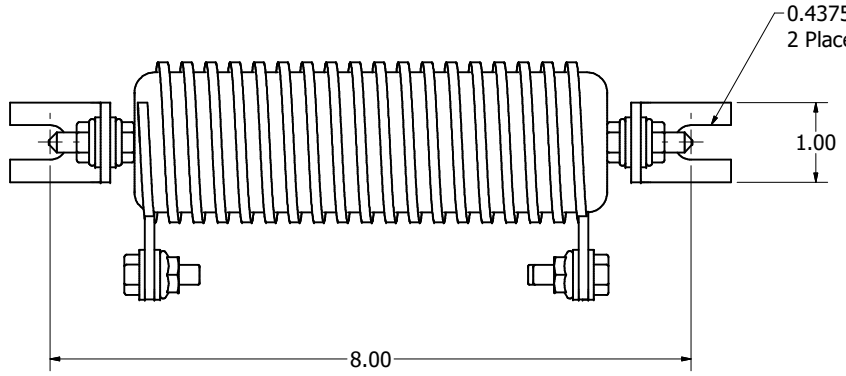

Customer Is Responsible For Installation  
To Meet All National And Local Electrical Codes.  
Material(s) Shall be RoHS Compliant

DIMENSIONS IN INCHES (EXCEPT AS NOTED) TOLERANCES (EXCEPT AS NOTED) DECIMAL .XX ± .03 .XXX ± .010 FRACTIONAL ± 1/32 ANGULAR ± 1°	THE INFORMATION AND DESIGN CONTAINED IN THIS DRAWING ARE CONFIDENTIAL AND THE PROPRIETARY PROPERTY OF ALLIENT INC. AND ITS SUBSIDIARIES. NEITHER THIS DESIGN NOR ANY INFORMATION CONTAINED IN THIS DRAWING MAY BE REPRODUCED OR DISCLOSED TO OTHERS WITHOUT THE EXPRESS WRITTEN CONSENT OF ALLIENT INC. AND ITS SUBSIDIARIES.		DESN BY DSW	DATE 11/12/12		W132N10611 Grant Drive Germantown, WI 53022 © 2026 Allient Inc.
	C 7400 Update part to UL Version	DATE 2/18/26	DSW	SCALE 1:1.2	DESN NO. 22943DG	SIZE C
NO	ECO	REVISION	DATE	BY	SCALE	DESIGN NO.