

575 Rated Voltage, 600 Max Voltage, High Z, Impedance.							
Part Number	Horsepower (HP)	Motor Amps (A)	Maximum Amps (A)	Inductance (uH)	Weight (LBS)	Losses (W)	Attached Lug Kit
KDRULX43HE01	1100	1056	1064	36.2	770	2189	SLK24

Ground Lug.
See IOM Manual, Part# 30895
Table 2S350, Wire Size And Torque.

Suggested
Customer Wire Entrance
Bottom Of Enclosure.
See Note: 5
(Non Removeable Panel)

Suggested
Customer Entrance
Either Side Of Enclosure.
See Note: 5
(Non Removeable Panel)

(Customer Connections)
Markings On Coils
For Reference Only.

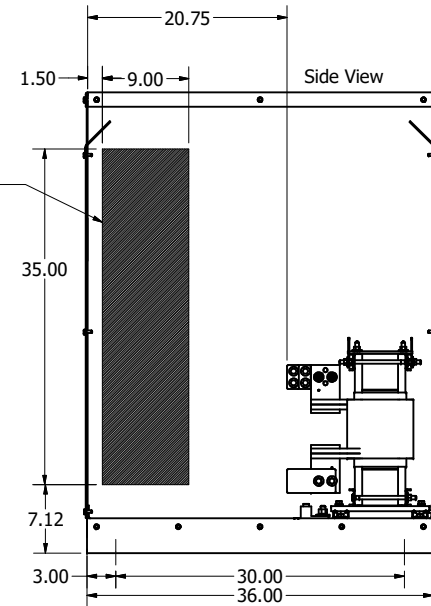

- Note: 1. UL file number: cULus Listed File E116124.
2. KDR Drive Inductors Comply With The Thermal and Altitude Standards Set Forth by NEMA ST20-1992.
3. For Terminal Torques And Wire Size See, KDR IOM Manual, Part Number 30895
4. Material(s) Shall be RoHS Compliant
5. Customer Is Responsible For Installation To Meet All National And Local Electrical Codes.

DIMENSIONS IN INCHES (EXCEPT AS NOTED) TOLERANCES (EXCEPT AS NOTED) DECIMAL .XX ± .25 .XXX ± .10 FRACTIONAL ± 1/32 ANGULAR ± 1°		THE INFORMATION AND DESIGN CONTAINED IN THIS DRAWING ARE CONFIDENTIAL AND THE PROPRIETARY PROPERTY OF ALLIENT INC. AND ITS SUBSIDIARIES. NEITHER THIS DESIGN NOR ANY INFORMATION CONTAINED IN THIS DRAWING MAY BE REPRODUCED OR DISCLOSED TO OTHERS WITHOUT THE EXPRESS WRITTEN CONSENT OF ALLIENT INC. AND ITS SUBSIDIARIES.		DESIGNED BY DSW	DATE 6/24/26		W132N10611 Grant Drive Germantown, WI 53022 © 2026 Allient Inc.
KDRULX43HE01 (Lugs Attached) 575V, 1056A, 1100HP, 3 Phase, Type 1		SCALE 1/10		REV. NO. 109959-2DG			SIZE C