

MSD PART NUMBER	HP	VOLT	CURRENT	WEIGHT	PRESSURE TERMINAL WIRE RANGE
MSD0080B000	30	240V	80 AMPS	220LBS	250MCM - 1 AWG

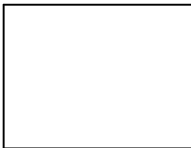
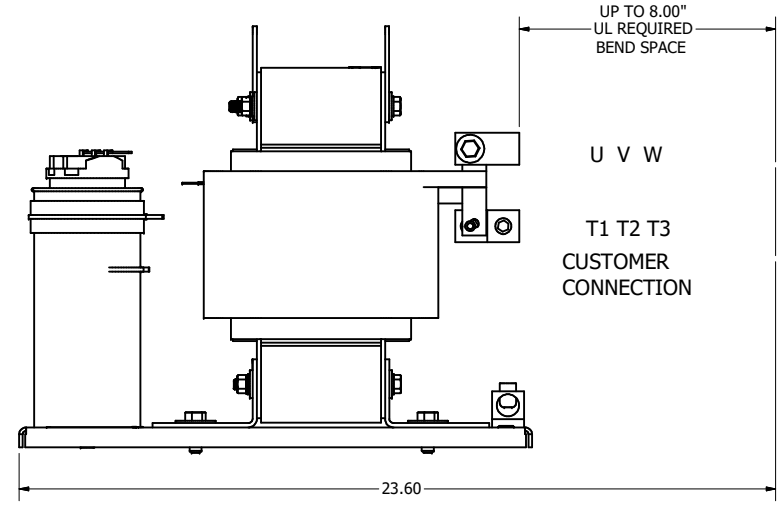
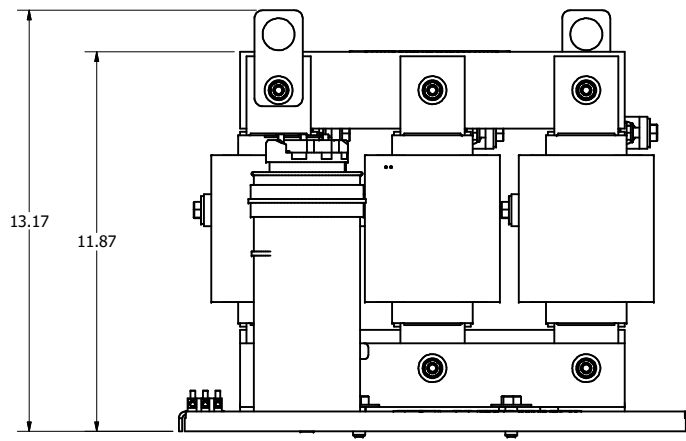
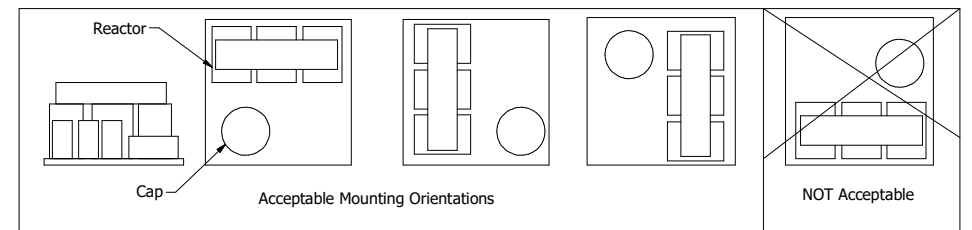
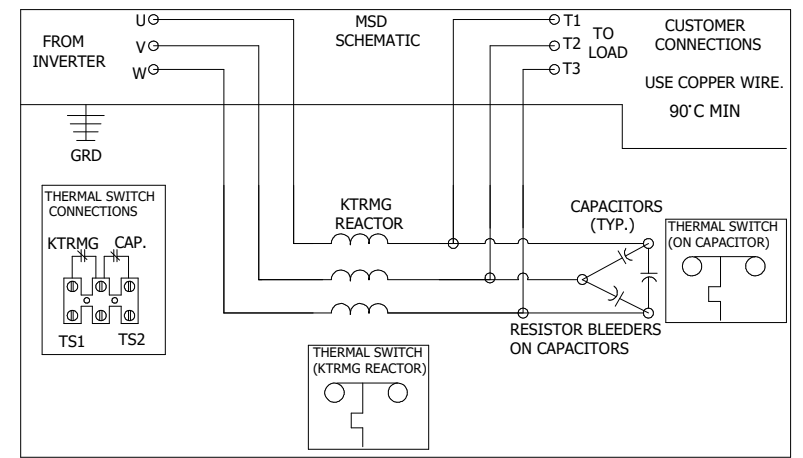
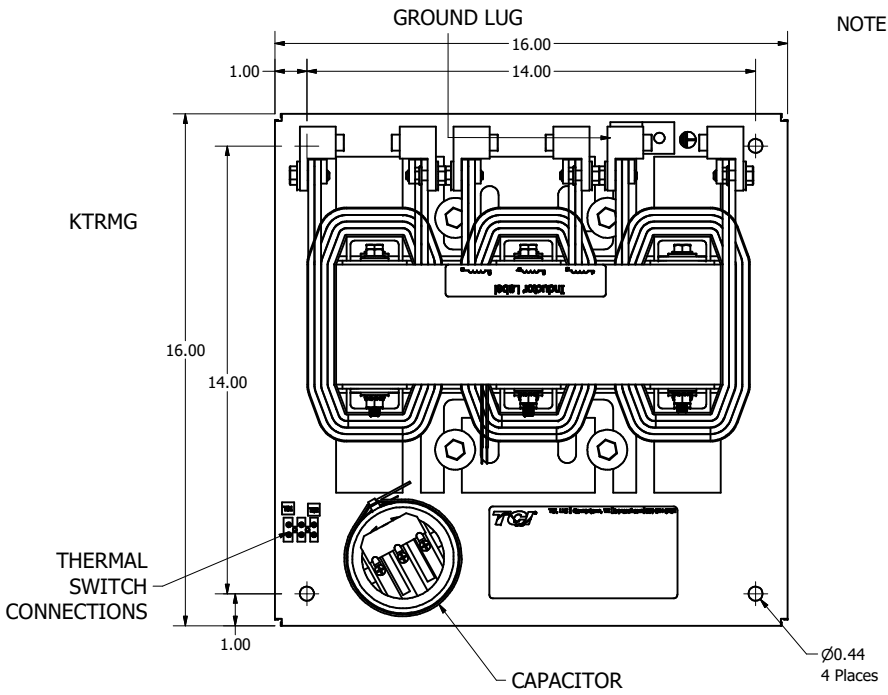

CAPACITOR DISCHARGE LABEL TO SHIP WITH PANEL

CUSTOMER IS RESPONSIBLE FOR PROPER COOLING OF FILTER COMPONENTS CAPACITORS MAXIMUM AMBIENT 50°C

CUSTOMER IS RESPONSIBLE FOR INSTALLATION TO MEET ALL NATIONAL AND LOCAL ELECTRICAL CODES.

DIMENSIONS IN INCHES (EXCEPT AS NOTED) TOLERANCES (EXCEPT AS NOTED) DECIMAL .XX ± .25 .XXX ± .10 FRACTIONAL ± 1/16 ANGULAR ± 1°		THE INFORMATION AND DESIGN CONTAINED IN THIS DRAWING ARE CONFIDENTIAL AND THE PROPRIETARY PROPERTY OF ALLIANT INC. AND ITS SUBSIDIARIES. NEITHER THIS DESIGN NOR ANY INFORMATION CONTAINED IN THIS DRAWING MAY BE REPRODUCED OR DISCLOSED TO OTHERS WITHOUT THE EXPRESS WRITTEN CONSENT OF ALLIANT INC. AND ITS SUBSIDIARIES.		DESIGNED BY: TJS	DATE: 04/23/26		W132N10611 Grant Drive Germantown, WI 53022 © 2026 Alliant Inc.
MotorShield Sinewave Filter 80 Amp, 240/3/60, Open				SCALE: 1/3	DEN. NO.: 109932DG		SIZE: C
NO	ECO	REVISION	DATE	BY	TJS		