

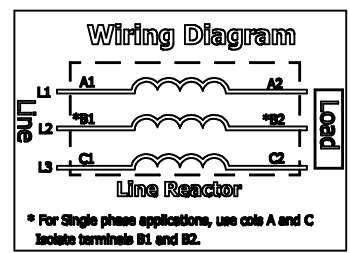

575 Rated Voltage, 600 Max Voltage, Output						
Part Number	Horsepower (HP)	Maximum Amps (A)	---uH+/-10%	Weight (LBS)	Losses (W)	Terminal Hole Size (Inches)
KLR110DCB	100	110	240	35	217	0.28

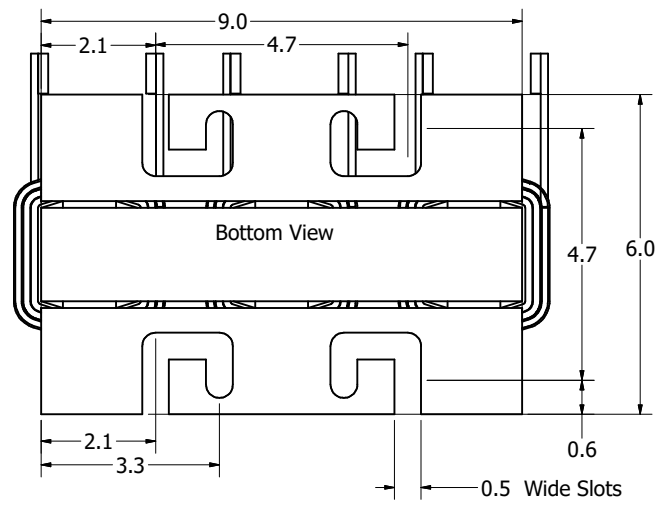
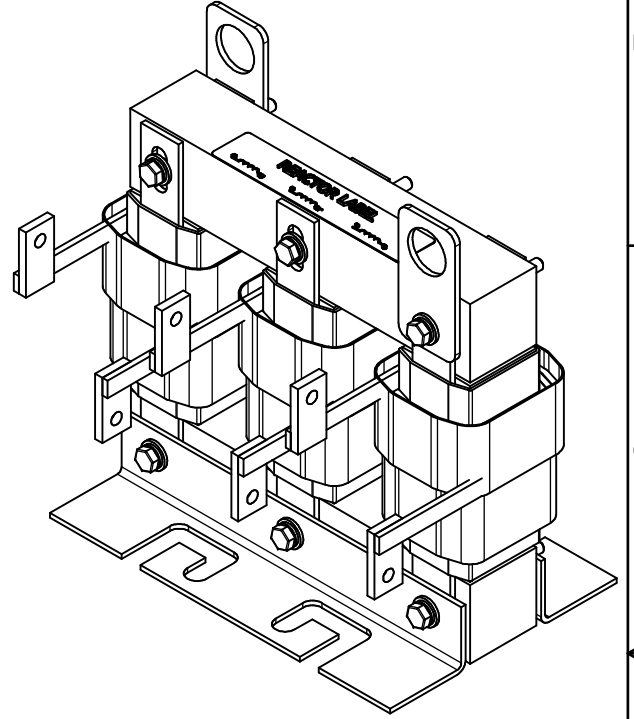
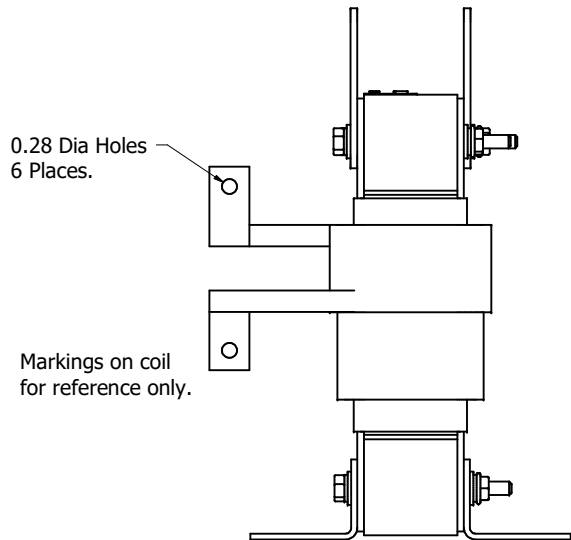
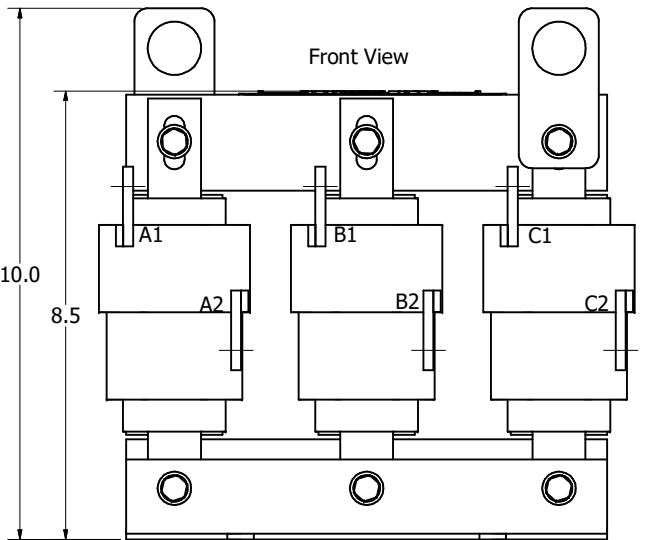
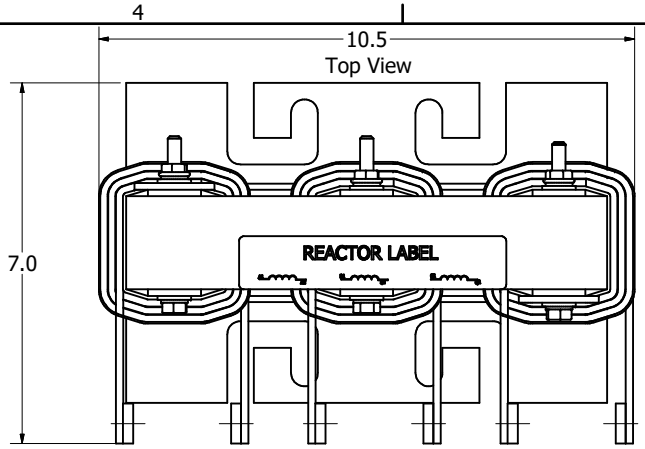
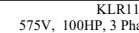

- Notes:
1. Material(s) Shall be RoHS Compliant
 2. Customer Is Responsible For Installation To Meet All National And Local Electrical Codes.

THE INFORMATION AND DESIGNS CONTAINED IN THIS DRAWING ARE CONFIDENTIAL AND THE PROPRIETARY PROPERTY OF ALLIED MOTION TECHNOLOGIES INC. AND ITS SUBSIDIARIES. NEITHER THIS DESIGN NOR ANY INFORMATION CONTAINED IN THIS DRAWING MAY BE REPRODUCED OR DISCLOSED TO OTHERS WITHOUT THE EXPRESS WRITTEN CONSENT OF ALLIED MOTION TECHNOLOGIES INC. AND ITS SUBSIDIARIES.				TOLERANCES (EXCEPT AS NOTED)		 W132N10611 (Rev 11/20) Germantown, WI 53022 © 2024 TCI, LLC	
				DECIMAL			.XX ± .25 .XXX ± .10
				FRACTIONAL			± 1/32
				ANGULAR			± 1°
A	6561, Was KLR-25, Flag to 32766	2/12/2024	DSW	DRN BY: DSW	DATE: 2/12/2024	 KLR110DCB 575V, 100HP, 3 Phase, UL Recognized 109566DG	
NO	REVISION	DATE	BY	SCALE: 1:1.8	REVISED	SHEET 1 OF 1	