

MSD PART NUMBER	HP	VOLT	CURRENT	WEIGHT	PRESSURE TERMINAL WIRE RANGE	GROUND LUG WIRE RANGE
MSD0055C000	50	600V	55 AMPS	120LBS	1-22AWG	2/0 - 4AWG

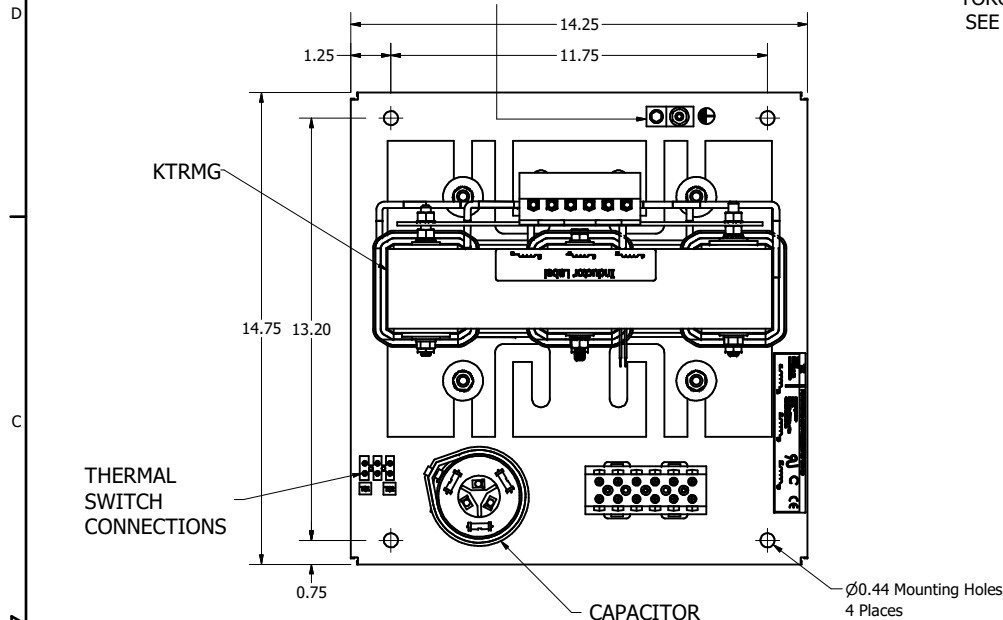

NOTE: FOR WIRE RANGE AND TORQUE INFORMATION SEE IOM MANUAL.

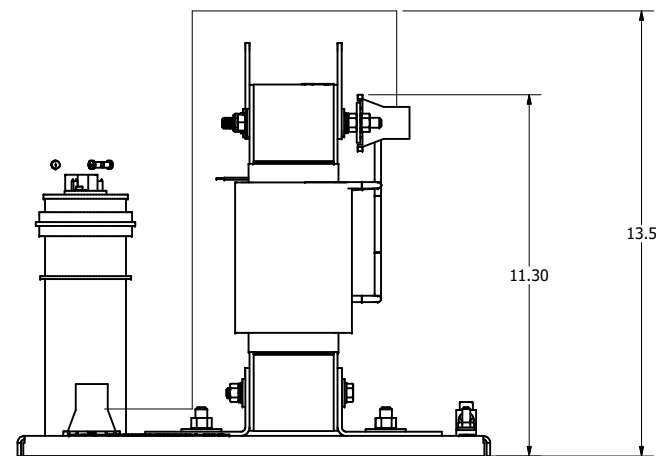
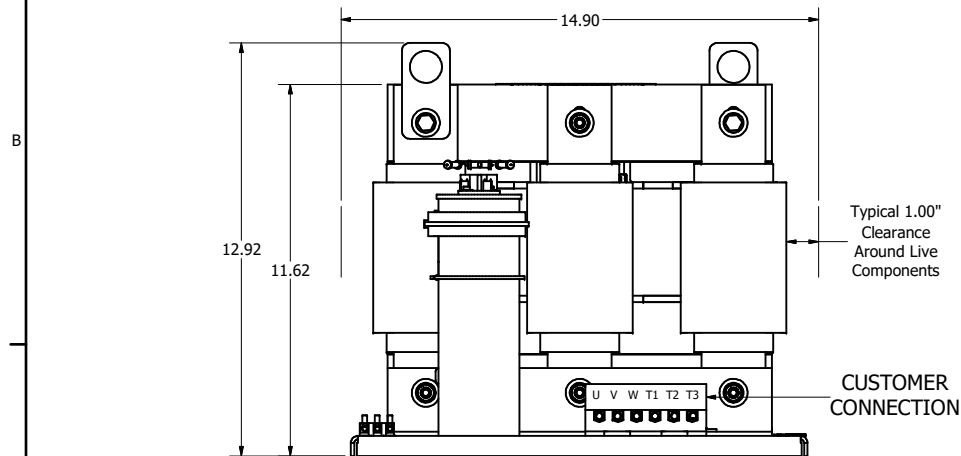
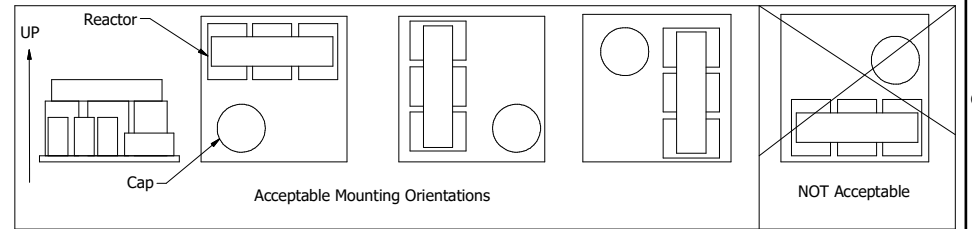
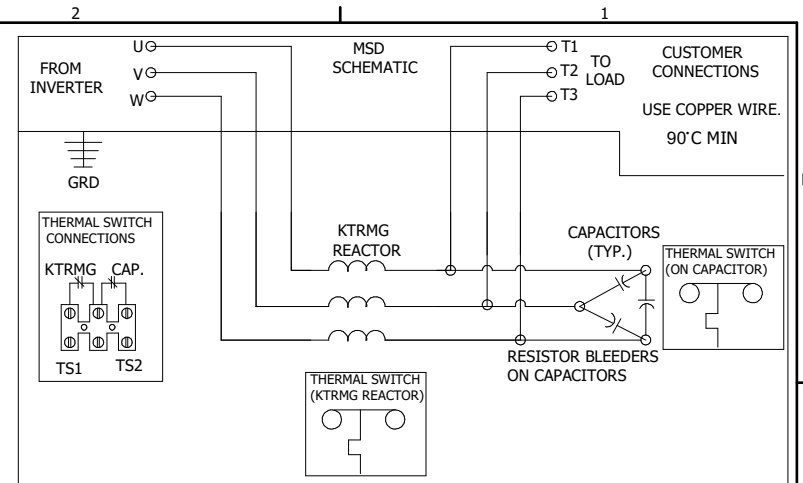

CUSTOMER IS RESPONSIBLE FOR INSTALLATION TO MEET ALL NATIONAL AND LOCAL ELECTRICAL CODES.



CAPACITOR DISCHARGE LABEL TO SHIP WITH PANEL

CUSTOMER IS RESPONSIBLE FOR PROPER COOLING OF FILTER COMPONENTS CAPACITORS MAXIMUM AMBIENT 50°C

DIMENSIONS IN INCHES (EXCEPT AS NOTED) TOLERANCES (EXCEPT AS NOTED) DECIMAL .XX ± .03 .XXX ± .010 FRACTIONAL ± 1/32 ANGULAR ± 1°		THE INFORMATION AND DESIGN CONTAINED IN THIS DRAWING ARE CONFIDENTIAL AND THE PROPRIETARY PROPERTY OF ALLIENT INC. AND ITS SUBSIDIARIES. NEITHER THIS DESIGN NOR ANY INFORMATION CONTAINED IN THIS DRAWING MAY BE REPRODUCED OR DISCLOSED TO OTHERS WITHOUT THE EXPRESS WRITTEN CONSENT OF ALLIENT INC. AND ITS SUBSIDIARIES.		DESIGNED BY: JRN	DATE: 12/07/22		W132N10611 Grant Drive Germantown, WI 53022 © 2025 Allient Inc.
C	7265	Update Wire Clearance	10/17/25	TJS		MotorShield Sinewave Filter 55 Amp, 600/3/60, Open	
B	6884	Update Table Title	12/05/24	JRN		SCALE: 1/3 DEN. NO. 109307DG	
A		As Designed	12/07/22	JRN		SHT. 1 OF 1	
NO	ECO	REVISION	DATE	BY	1/3		