

TCI Part Number	Rated Amps (A)	Rated Voltage (V)	Hz	---uH ±5%	Approx Weight (LBS)
KTRMG480AX1	480	480	60	100	455

Thermal Switch Terminal Block

Wire Range: 18 AWG To 4 AWG.
Torque: 20 LB-IN (2.3 Nm)
Switch Opens on Temperature Rise
Contact Rating: 6A @ 120 VAC

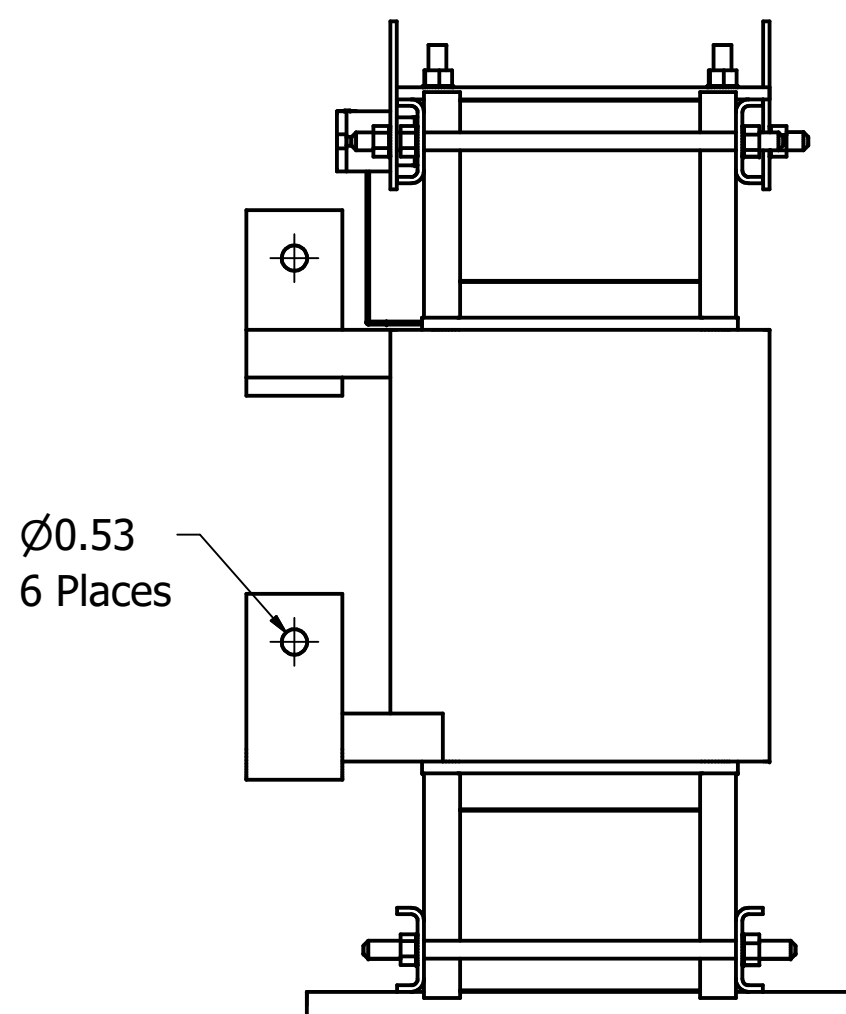
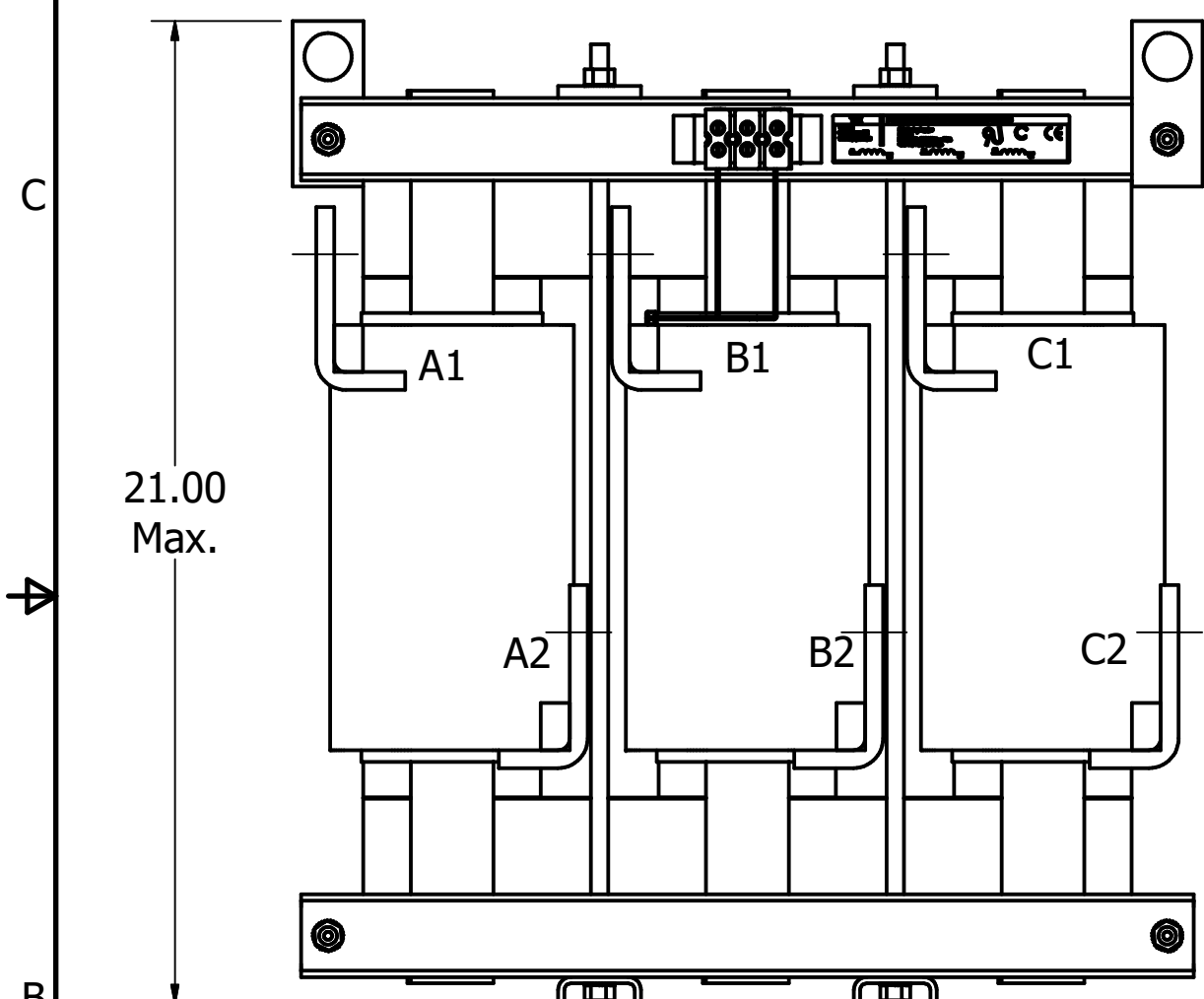
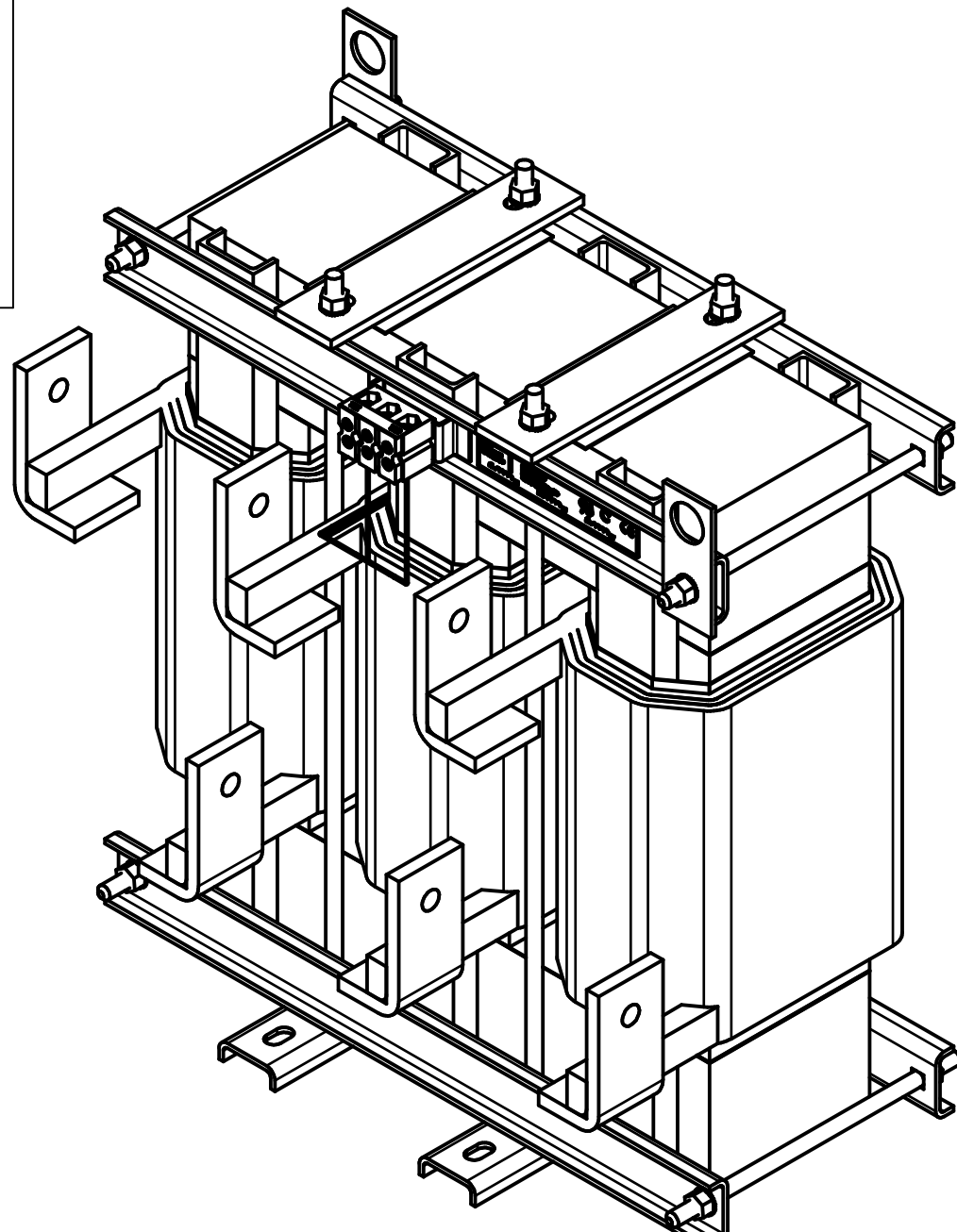

NOTE: Markings A1,A2,B1,B2,C1,C2 On Coils, Are For Reference Only.

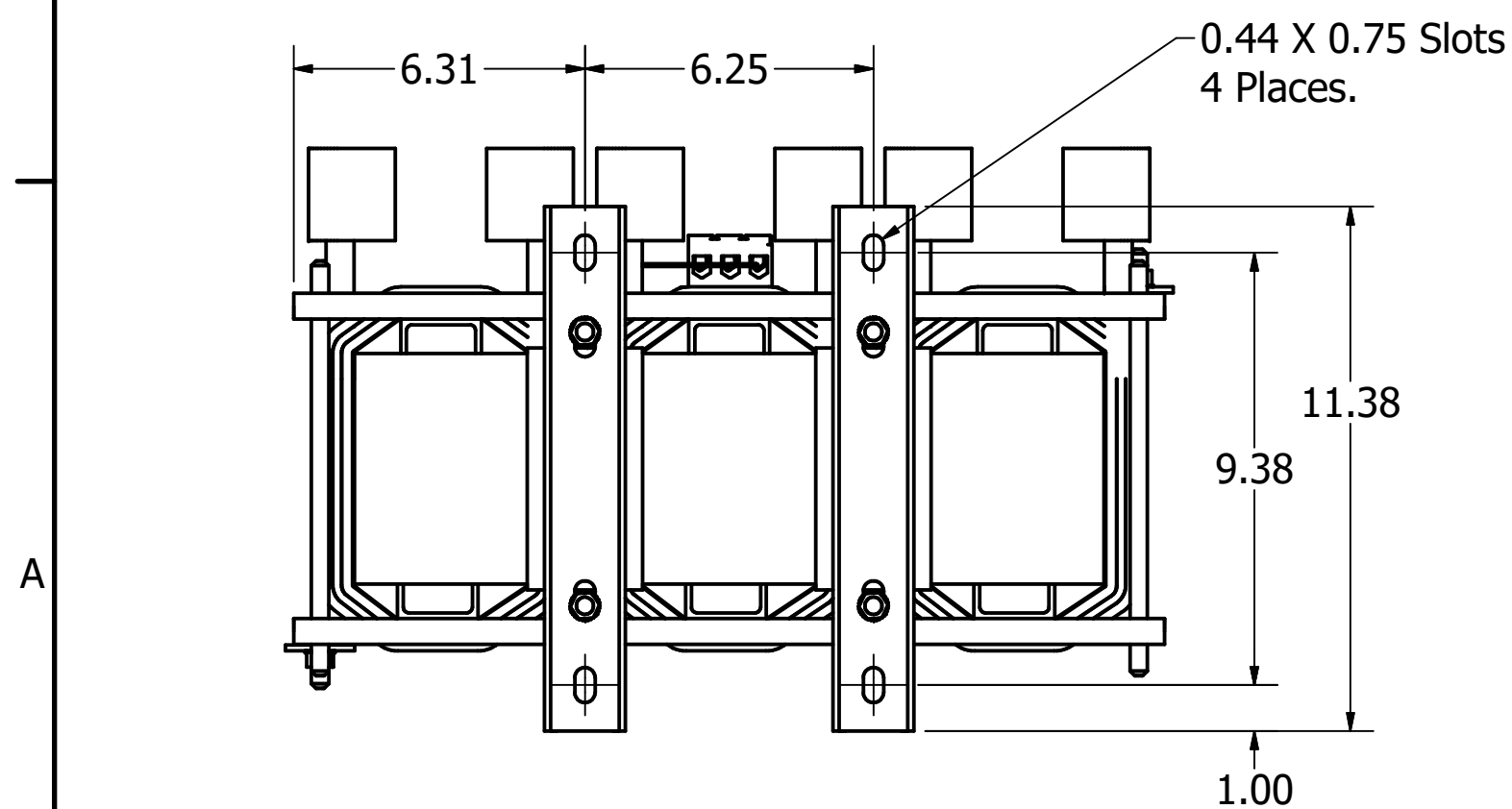

TCI, LLC
Germantown, WI
www.transcoll.com
800-824-8282

(800) 824-8282 • transcoll.com

KDR Drive Reactor
KTRMG— (Motor Amps) Or (Rating Amps)
3 PH, 50/60Hz, 600V Max. —Max.
40C Amb Max, 155C Rise.

Customer Is Responsible For Installation to Meet All National And Local Electrical Codes.

Material(s) Shall be RoHS Compliant

TOLERANCES (EXCEPT AS NOTED)				TCI W132 N10611 Grant Drive Germantown, WI 53022	
DECIMAL				KTRMG Y Frame, Copper Bus Reactor Drawing	
.XX ± .03					
.XXX ± .010					
FRACTIONAL ± 1/32				DRN BY: JRN	DATE: 08/15/19
ANGULAR ± 1°				SCALE: 1/4	APRVD: [Signature]
A	AS Designed	08/15/19	JRN	108097-2DG	SIZE C
NO	REVISION	DATE	BY		SHT. 1 OF 1