

Customer Connection U V W T1 T2 T3	
Wire Range	Tightening Torque
Three 600 kcmil - 4 AWG	500 In-Lbs
Ground Lug	
Wire Range	Tightening Torque
Three 600 kcmil - 4 AWG	500 In-Lbs

SUGGESTED CUSTOMER ENTRANCE.  
THERMAL SWITCH AND FAN PWR TB LOCATED ON SIDE OF ENCLOSURE.

Ø.56 DIA HOLE  
4 PLACES

MSD PART NUMBER	HP	VOLTAGE	CURRENT	WEIGHT
MSN0850C300	900	600V	850 AMPS	875LBS

CUSTOMER IS RESPONSIBLE FOR INSTALLATION TO MEET ALL NATIONAL AND LOCAL ELECTRICAL CODES.

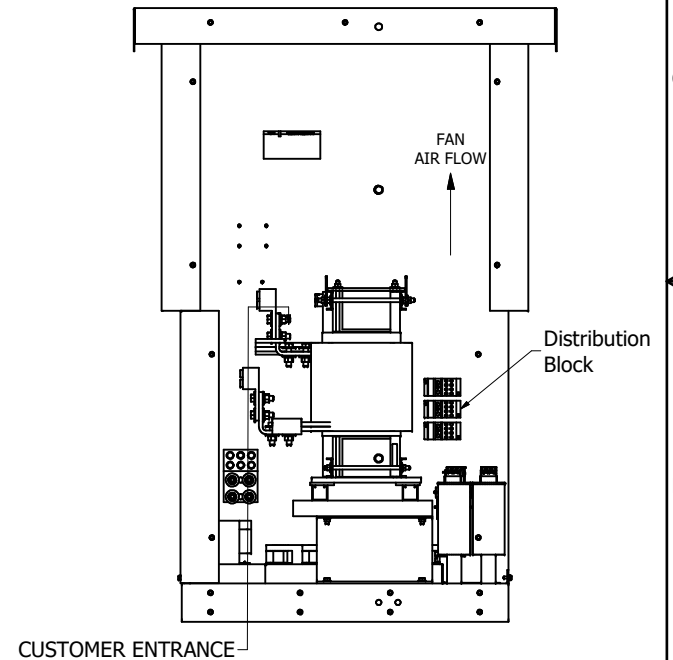
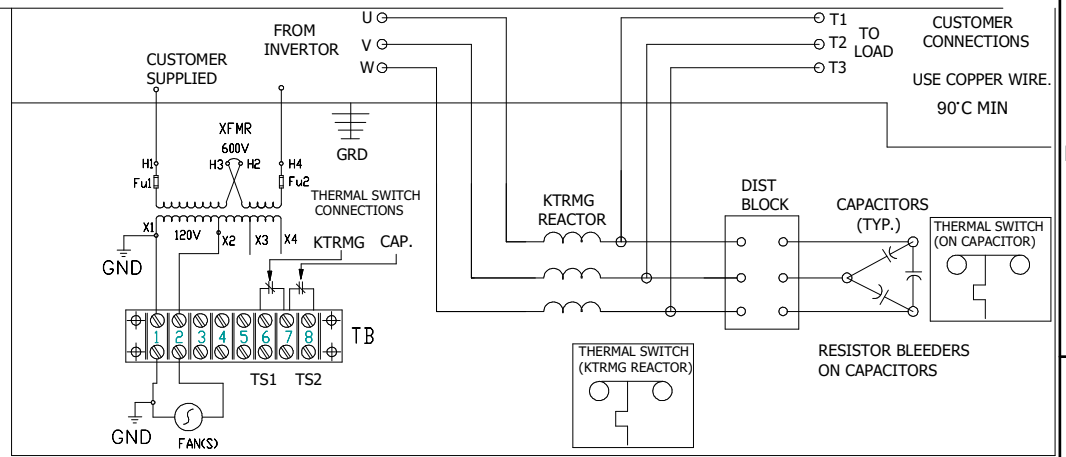
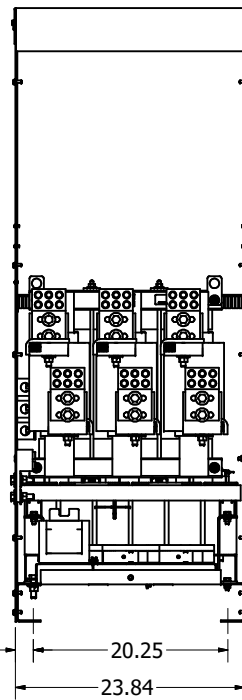

DIMENSIONS IN INCHES (EXCEPT AS NOTED) TOLERANCES (EXCEPT AS NOTED) DECIMAL .XX ± .03 .XXX ± .010 FRACTIONAL ± 1/32 ANGULAR ± 1°		THE INFORMATION AND DESIGN CONTAINED IN THIS DRAWING ARE CONFIDENTIAL AND THE PROPRIETARY PROPERTY OF ALLIENT INC. AND ITS SUBSIDIARIES. NEITHER THIS DESIGN NOR ANY INFORMATION CONTAINED IN THIS DRAWING MAY BE REPRODUCED OR DISCLOSED TO OTHERS WITHOUT THE EXPRESS WRITTEN CONSENT OF ALLIENT INC. AND ITS SUBSIDIARIES.		DESIGNED BY: JRN	DATE: 11/13/18		W132N10611 Grant Drive Germantown, WI 53022 © 2026 Allient Inc.
MSN0850C300, MotorShield Sinewave Filter 600/3/60, Type 1/3R		SCALE: 1/10	REV. NO.: 107944DG	SIZE: C	SHT. 1 OF 1		
NO	ECO	REVISION	DATE	BY	SCALE	REV. NO.	SIZE
			11/13/18	JRN	1/10	107944DG	C