

(Customer Connections)  
Markings On Coils  
For Reference Only.

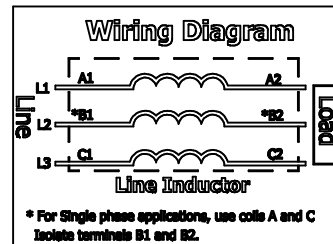
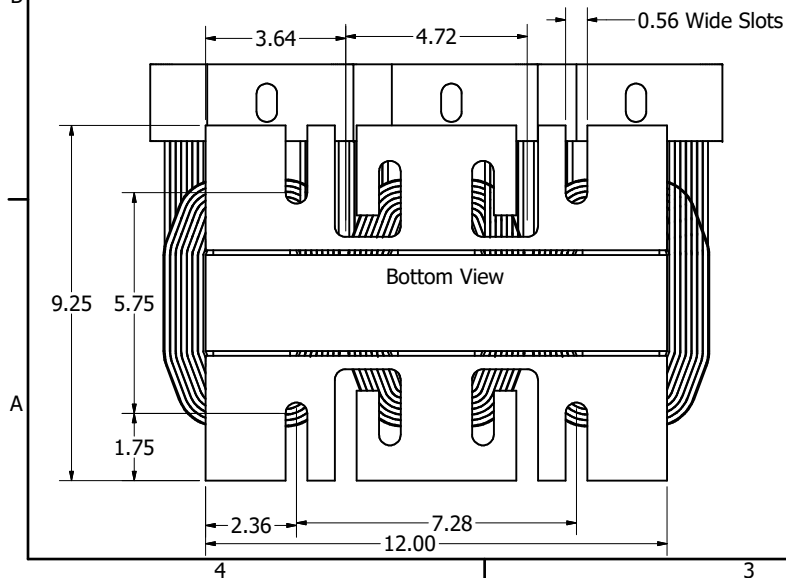
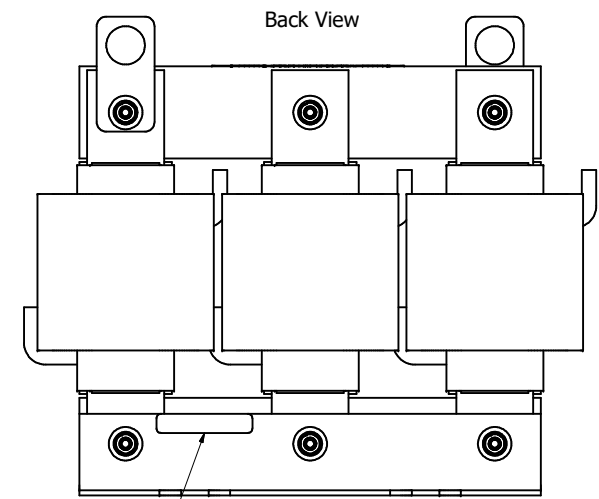
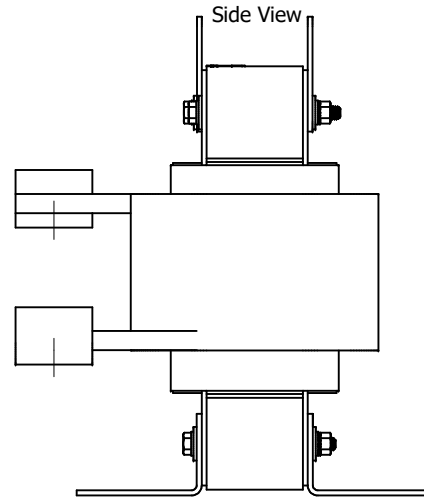
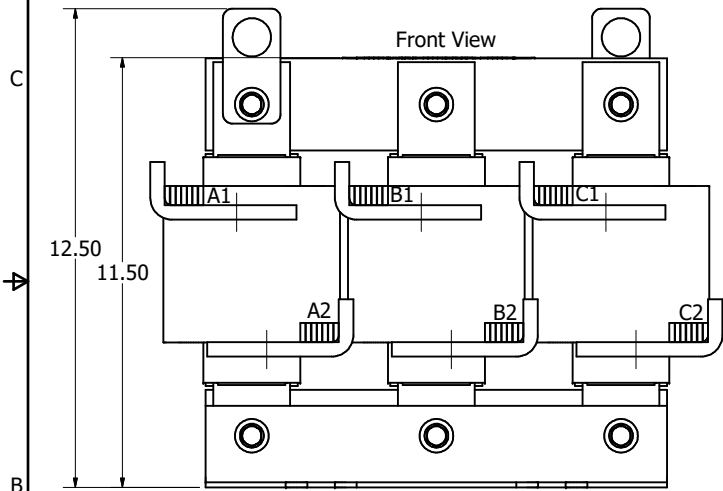

| 480 Rated Voltage, 600 Max Voltage, High Z, Impedance. |                 |                |                  |                 |              |                   |                             |
|--|-----------------|----------------|------------------|-----------------|--------------|-------------------|-----------------------------|
| Part Number  | Horsepower (HP) | Motor Amps (A) | Maximum Amps (A) | Inductance (uH) | Weight (LBS) | Available Lug Kit | Terminal Hole Size (Inches) |
| KDRL6H   | 500             | 590            | 590              | 52.5            | 130          | SLK14             | 0.56 X 1.00 Slot            |

Notes:

1. KDR Lug Kits sold separately. Contact TCI.
2. UL file number: cULus Listed File E116124.
3. KDR Line Inductors Comply With The Thermal and Altitude Standards Set Forth by NEMA ST20-1992.
4. KDR IOM Manual Part Number 30895
5. NEC Current For 208/240 Volts, Horsepower Based On 208 Volts.
6. Material(s) Shall be RoHS Compliant
7. Customer Is Responsible For Installation To Meet All National And Local Electrical Codes.

Strip 2.40 2.50 Stack

| DIMENSIONS IN INCHES (EXCEPT AS NOTED) |      | TOLERANCES (EXCEPT AS NOTED) |         | THE INFORMATION AND DESIGN CONTAINED IN THIS DRAWING IS CONFIDENTIAL AND THE PROPRIETARY PROPERTY OF ALLIENT INC. AND ITS SUBSIDIARIES. NEITHER THIS DESIGN NOR ANY INFORMATION CONTAINED IN THIS DRAWING MAY BE REPRODUCED OR DISCLOSED TO OTHERS WITHOUT THE EXPRESS WRITTEN CONSENT OF ALLIENT INC. AND ITS SUBSIBDIARIES. |         | DESIGNED BY | DATE | SCALE | DRAWING NO. | SIZE | SHEET 1 OF 1 |
|--|------|------------------------------|---------|---|---------|-------------|------|-------|-------------|------|--------------|
| F                                      | 7473 | Update Cut Length            | 5/6/26  | DSW   | 3/23/18 | DSW         |      | 1:2.5 | 107537-9DG  | C    |              |
| E                                      | 6935 | Flag 15468 to 20783-1        | 1/28/25 | DSW   |         |             |      |       |             |      |              |
| B                                      | 6787 | Removed KDRLSH               | 9/10/24 | DSW   |         |             |      |       |             |      |              |
| A                                      |      | Combined drawings            | 3/23/18 | DSW   |         |             |      |       |             |      |              |
| NO                                     | ECO  | REVISION                     | DATE    | BY  |         |             |      |       |             |      |              |



KDRL6H  
Inductor Drawing