

Drawings:
 General Schematic: 29070
 Customer Connection #25027-3
 Interface/Display Module #28283-1
 Current Transformer #26461

Notes:
 Weight lbs (Kg) 406 (184.2)
 Total heat loss 5,250 watts, 17,914 Btu/h.
 Maintain 3 inch side clearance both sides for cooling.
 *Maintain 6 inch floor clearance for cooling.

This unit is rated for 110A when applied with a 480V/600V autotransformer.

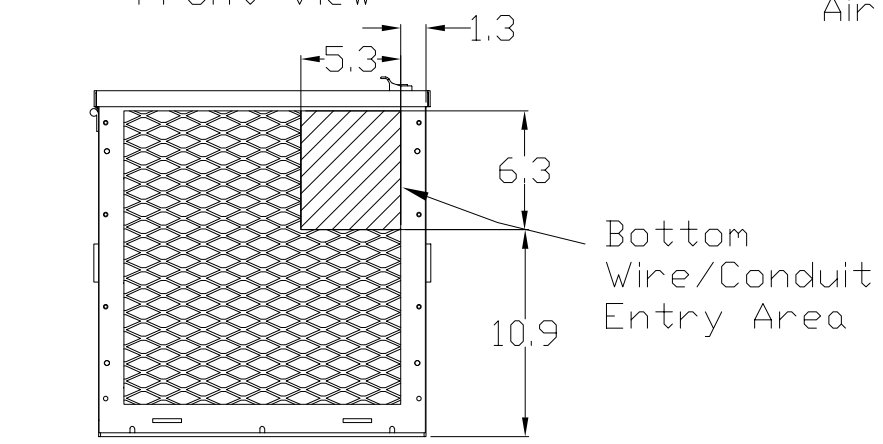

TCI, LLC CLAIMS PROPRIETARY RIGHTS IN THE MATERIAL HEREIN DISCLOSED. IT IS SUPPLIED WITHOUT PREJUDICE TO ANY PATENT RIGHTS OF TCI AND MAY NOT BE REPRODUCED OR USED TO MANUFACTURE ANYTHING SHOWN THEREIN WITHOUT WRITTEN PERMISSION FROM TCI.

NO	REVISION	DATE	BY	TOLERANCES (EXCEPT AS NOTED)
F	update to compact HMI	10/5/20	MJS	DECIMAL
E	add 600V rating note	12/14/18	MJS	.XX ± .05
D	add floor clearance note	9/20/16	MJS	.XXX ± .025
C	Update Notes	1/26/16	RHW	FRACTIONAL ± 1/32
B	add bottom view	2/1/15	MJS	ANGULAR ± 1/2°
A	Update weight and notes	8/27/14	RHW	

TCI® W132 N10611 Grant Drive
 Germantown, WI 53022

OUTLINE, INSTALLATION,
 ACTIVE FILTER, 150 AMP, TYPE 1

DRN. BY RHW DATE 5/13/14 DWG. NO. B 105645
 SCALE N/A SIZE SHT. 1 of 1