

Parts List			
TCI Part #	Description	Quantity	Item #
11443	Lug Three 600 kcmil	6	1LK
10251	Hex Hd Bolt 1/2-13 X 2 In	12	2LK
1610	Nut 1/2-13	12	3LK
1512	Flat Washer 1/2"	24	4LK
1511	Split Lock Washer	12	5LK

*T3A2-600N				
*CSA Certified				
*UL 486A/B Listed, UL File E6207				
*Must be mounted with a minimum of 2 Bolts				
Item ID	Conductor Range	Bolt/ Sud Size	Hex Size	Tightening Torque
T3A2-600N	600kcmil-2AWG	1/2	3/8	375 in-lb (42.4 N-m)

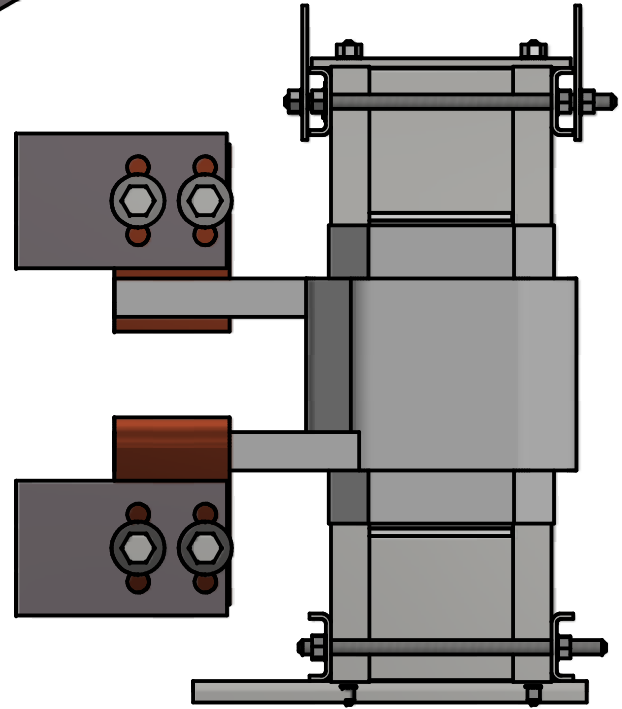
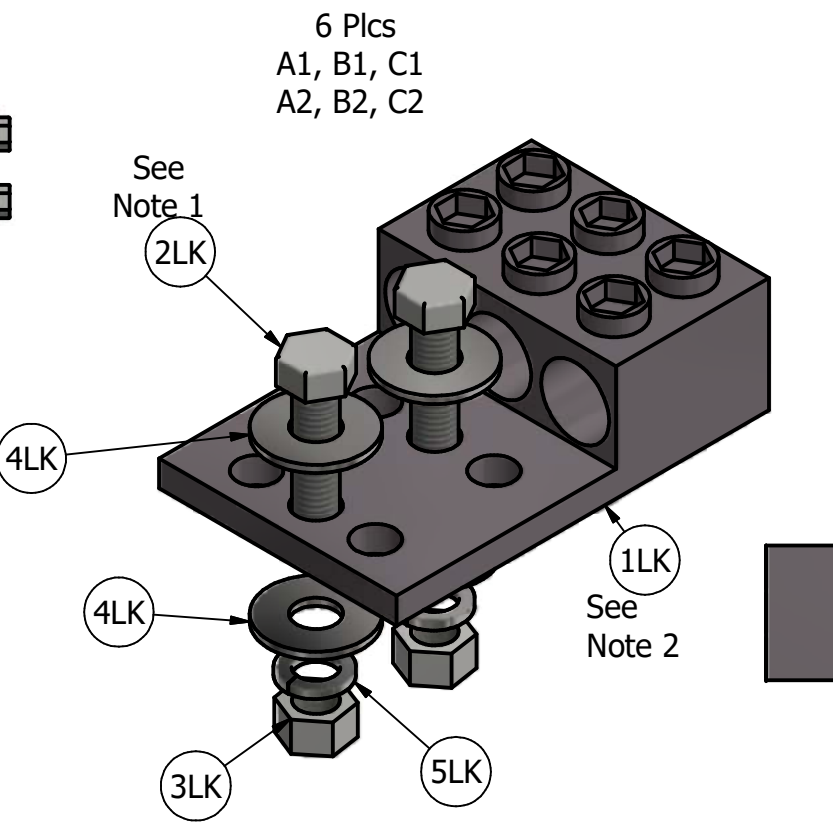

Follow NEC guidelines to determine acceptable wire ampacity requirements.
Material(s) Shall be RoHS Compliant

- Notes:
- 1.) Torque bolt (Item #2LK) to 450 in-lb (50.8 N-m).
 - 2.) To prevent lug from rotating place lug on underside of tab as shown.

THE INFORMATION AND DESIGNS CONTAINED IN THIS DRAWING ARE CONFIDENTIAL AND THE PROPRIETARY PROPERTY OF ALLIED MOTION TECHNOLOGIES INC. AND ITS SUBSIDIARIES. NEITHER THIS DESIGN NOR ANY INFORMATION CONTAINED IN THIS DRAWING MAY BE REPRODUCED OR DISCLOSED TO OTHERS WITHOUT THE EXPRESS WRITTEN CONSENT OF ALLIED MOTION TECHNOLOGIES INC. AND ITS SUBSIDIARIES.

TOLERANCES (EXCEPT AS NOTED)			
DECIMAL			
.XX ± .25			
.XXX ± .10			
FRACTIONAL			
± 1/16			
ANGULAR			
± 1°			

TCI
An Allied Motion Company

W132N10611 Grant Drive
Germantown, WI 53022
© 2022 TCI, LLC

Lug Kit, 3-600MCM-2

DRN. BY JRN	DATE: 8/31/17	LK16-Dwg
SCALE:	APRVD:	SIZE B

SHT.1 OF 1