

Unit Specifications					
kVar	Harmonic	Volt	HZ.	Phase	HP
60	5TH	480	60	3	400
TCI Part Number		Option	Weight	Schematic	
HGL0400AW1S0000		Standard	650lbs	30586-1S	
HGL0400AW1C0000		Contactora	660lbs	30586-1C	

See IOM Manual For Wire Range  
And Tightening Torque.

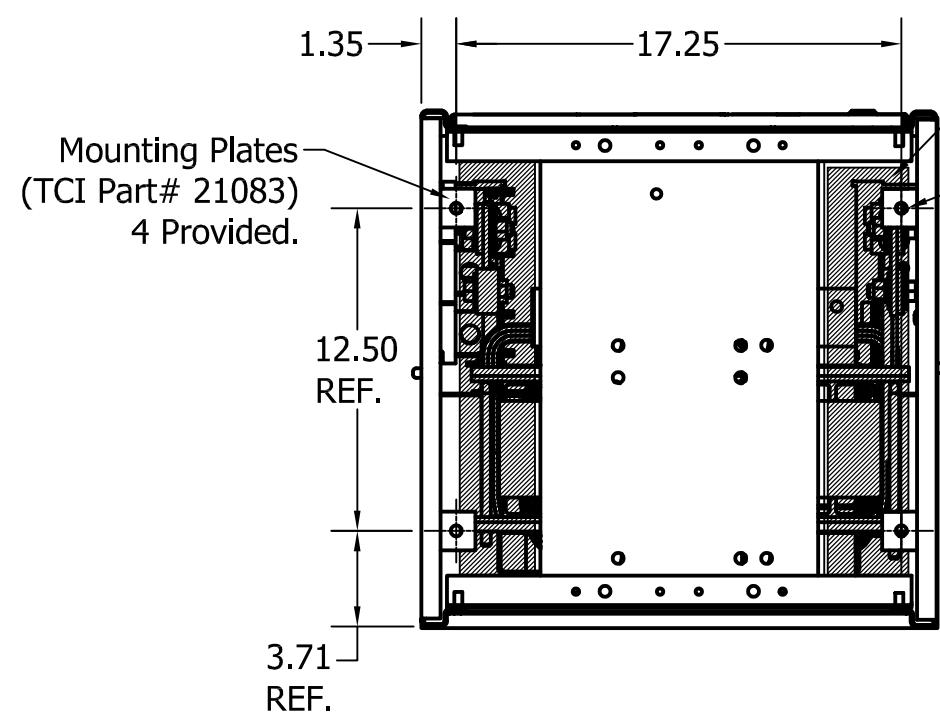
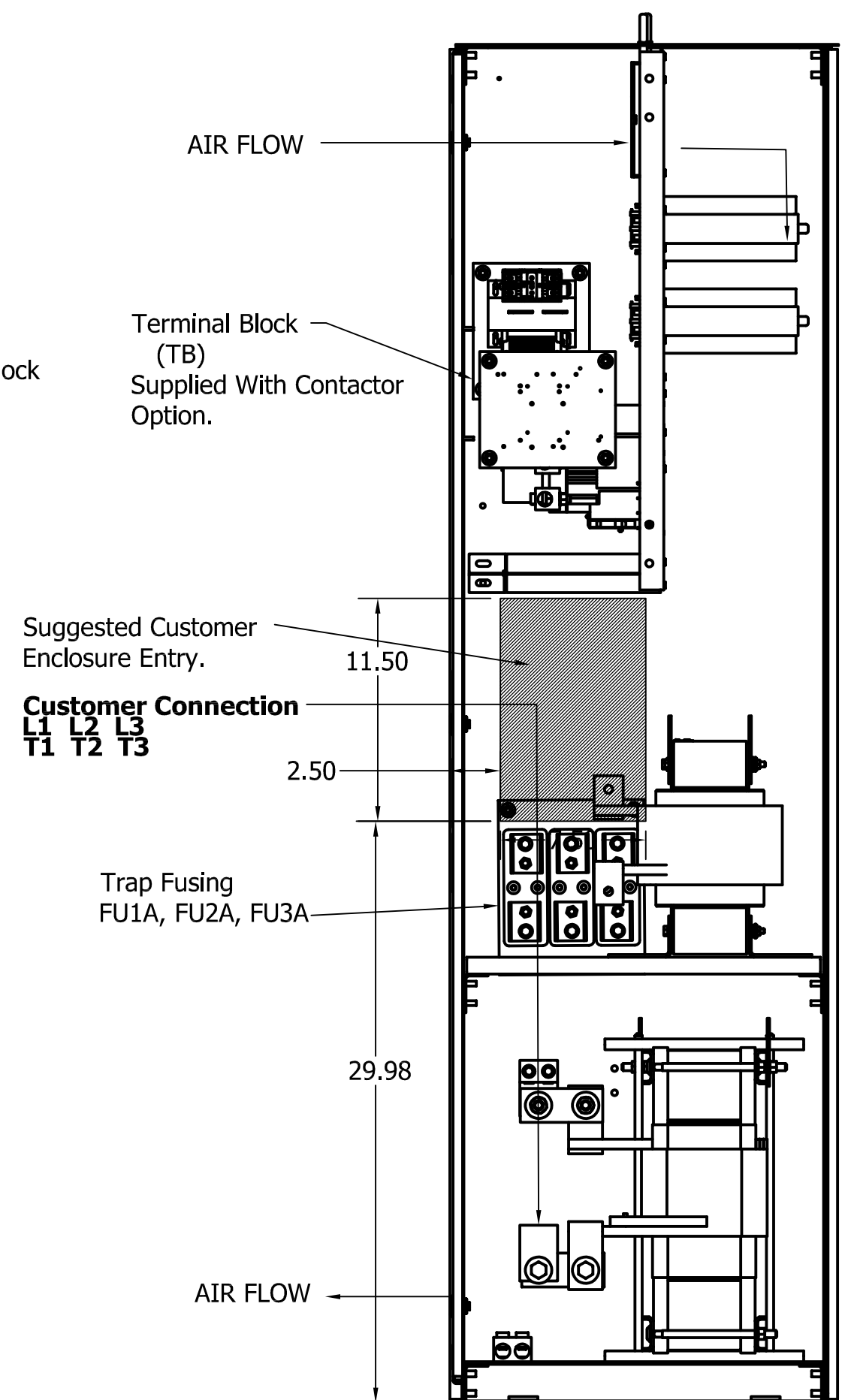
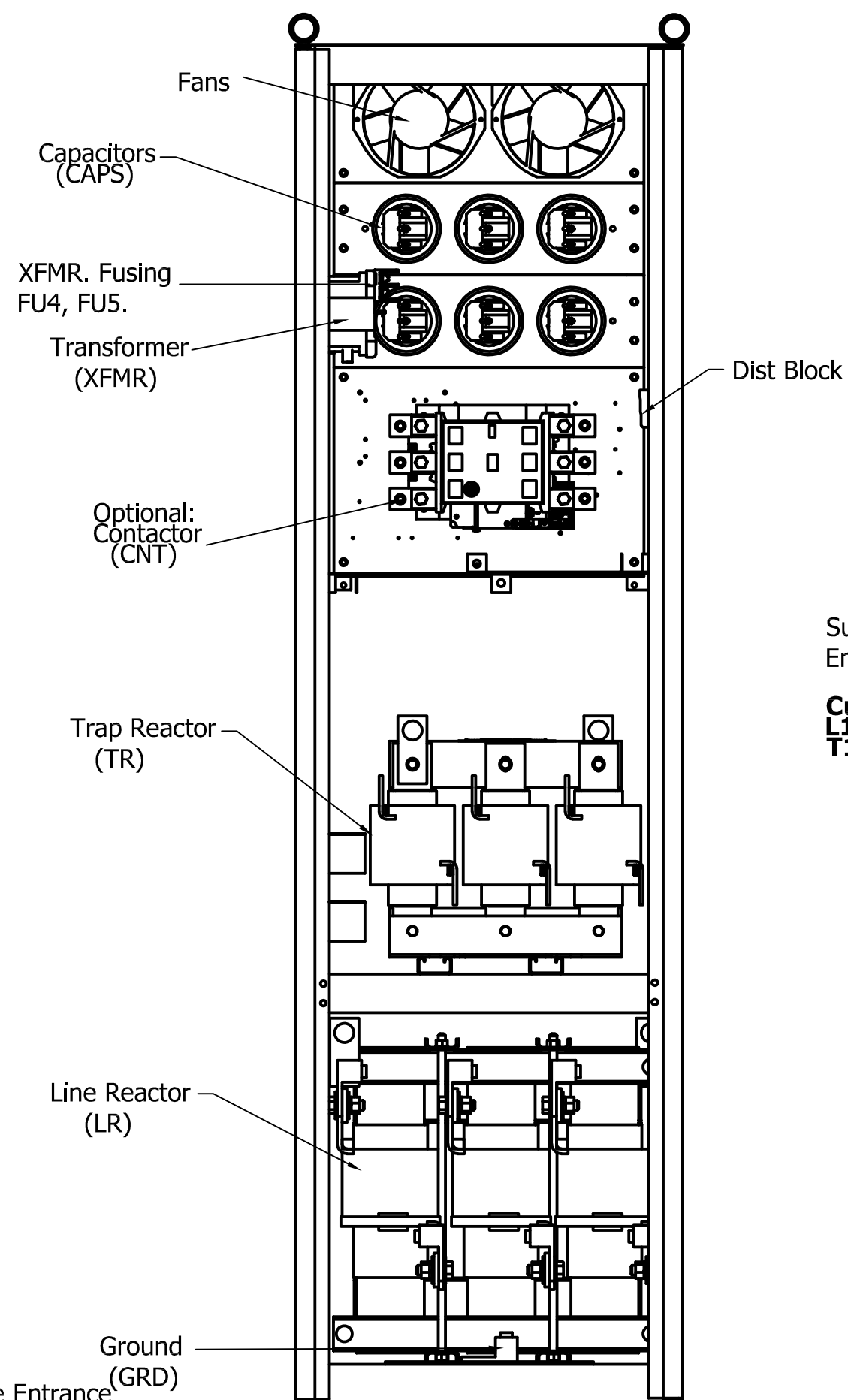
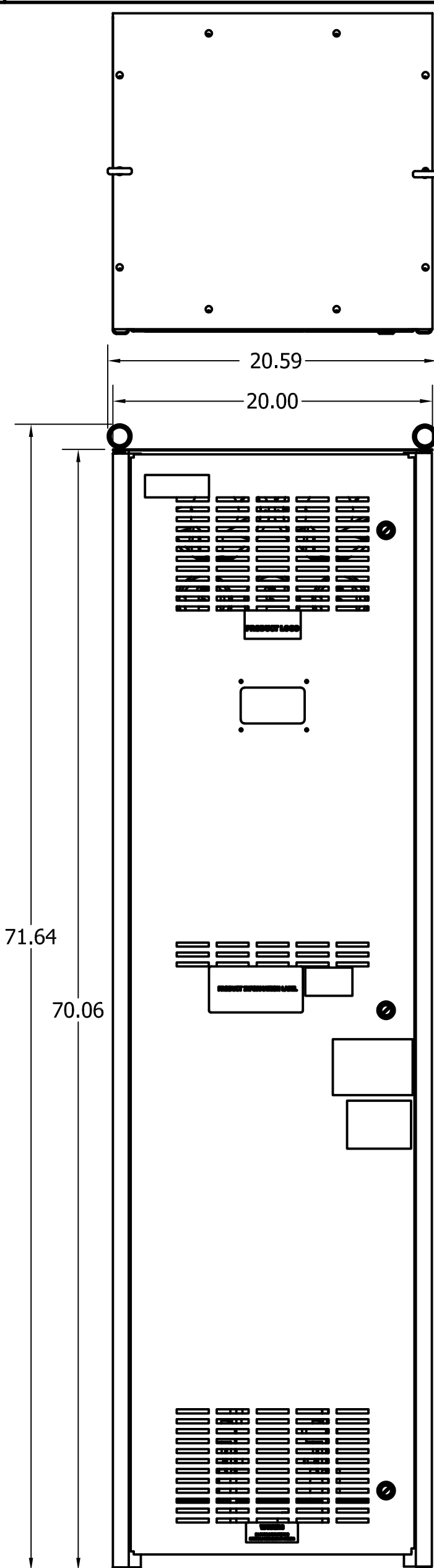

Cable Entrance  
Through Bottom Openings.  
(Hatched Area)

CUSTOMER IS RESPONSIBLE FOR INSTALLATION  
TO MEET ALL NATIONAL AND LOCAL ELETRICAL CODES.

Material(s) Shall be RoHS Compliant

TCI, LLC CLAIMS PROPRIETARY RIGHTS IN THE MATERIAL HEREIN DISCLOSED. IT IS SUPPLIED WITHOUT PREDJUDICE TO ANY PATENT RIGHTS OF TCI AND MAY NOT BE REPRODUCED OR USED TO MANUFACTURE ANYTHING SHOWN THEREIN WITHOUT WRITTEN PERMISSION FROM TCI.

NO	REVISION	DATE	BY	SCALE
A	AS DESIGNED	4/3/17	DSW	1/8
NO	REVISION	DATE	BY	SCALE

**TCI**® W132 N10611 Grant Drive  
Germantown, WI 53022

HGL0400AW1C0000, 480V, 400HP, 3 Phase  
HGL0400AW1S0000, 480V, 400HP, 3 Phase  
60 Hz, Type 1, Low C, Passive Harmonic Filter

DRN. BY: DSW DATE: 4/3/17 DWG. No.: 107025DG  
SCALE: 1/8 APRVD.

SHEET 1 OF 1

