

Unit Specifications					
kVar	Harmonic	Volt	HZ.	Phase	HP
30	5TH	600	60	3	200

TCI Part Number	Option	Weight	Schematic
HGL0200CW1S0000	Standard	490lbs	30807-1
HGL0200CW1C0000	Contactors	495lbs	30807

See IOM Manual For Wire Range
And Tightening Torque.

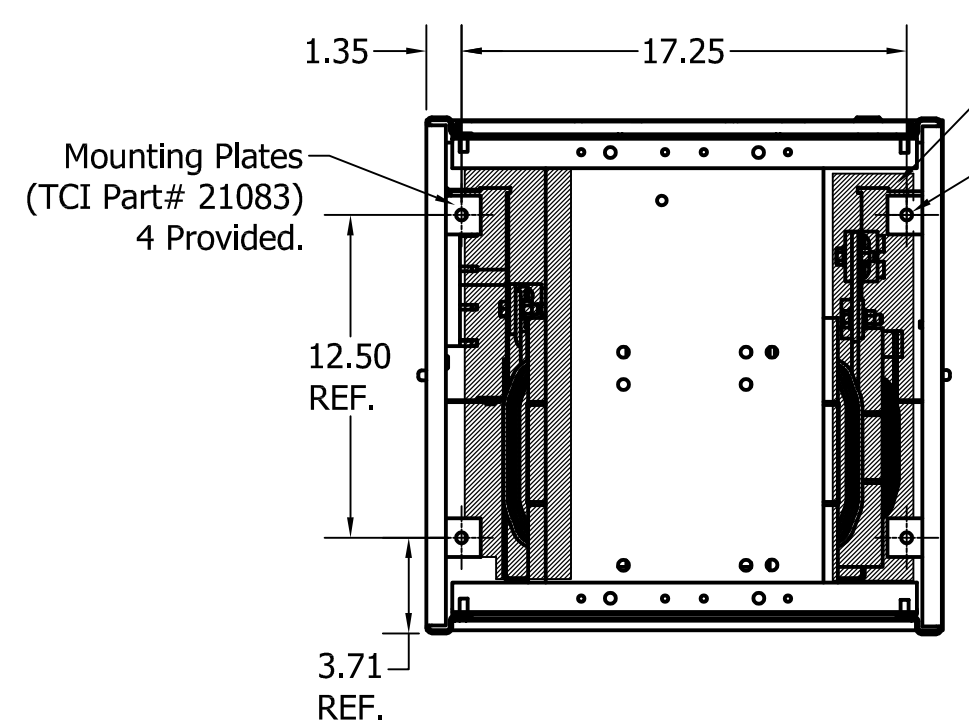
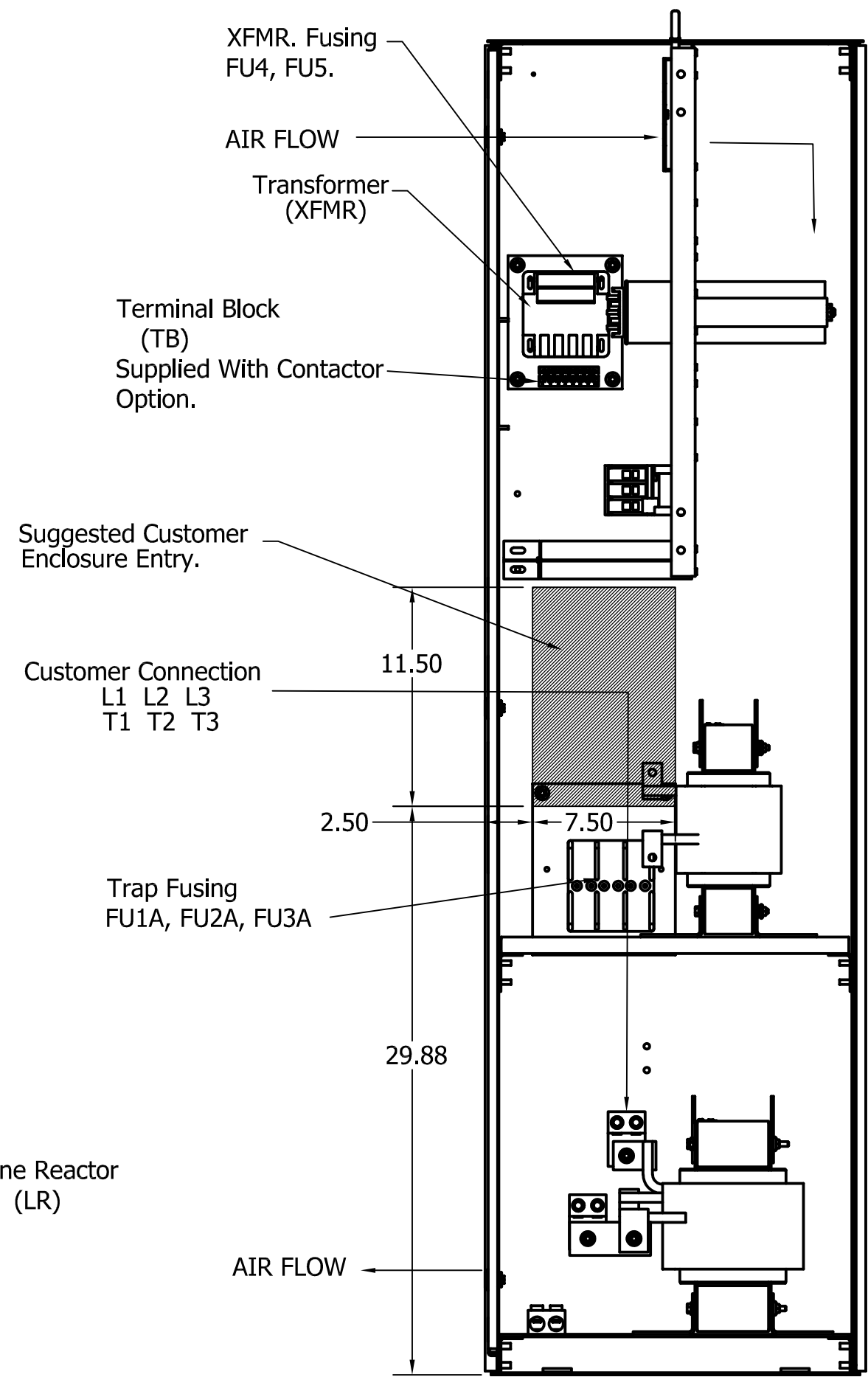
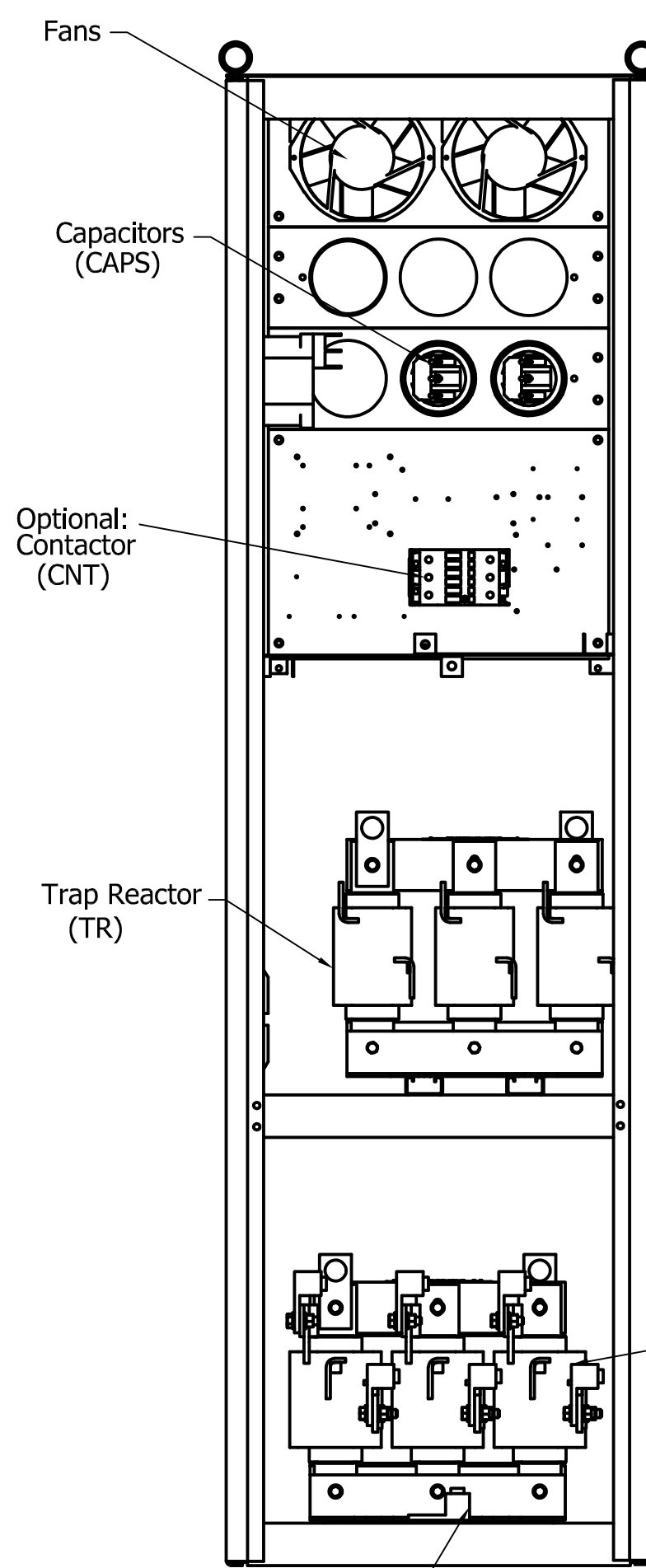
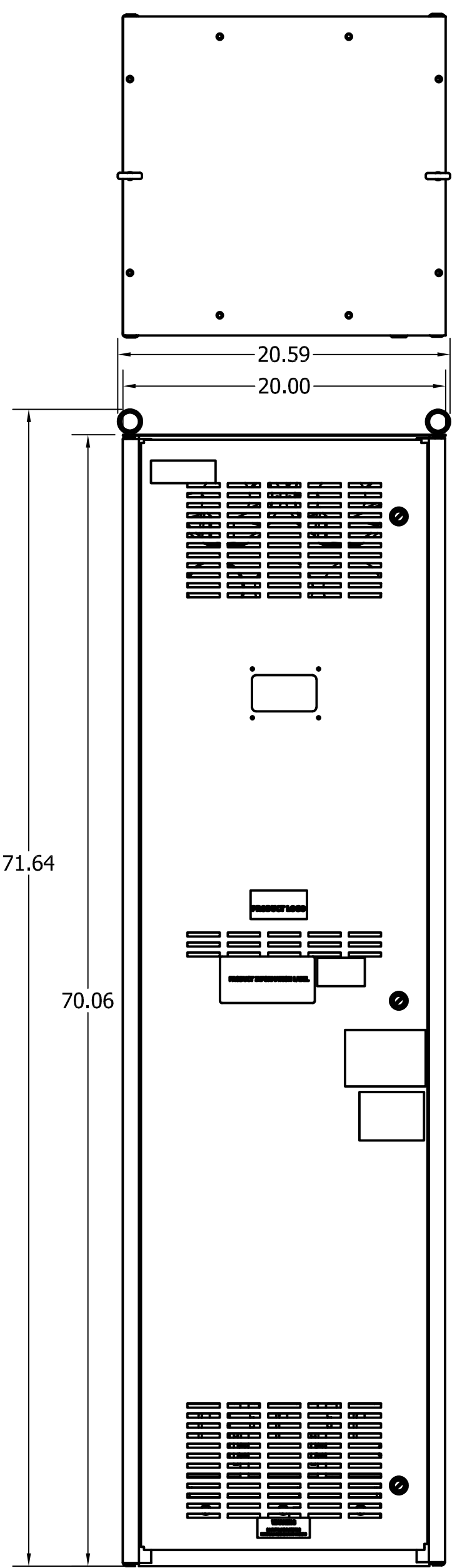
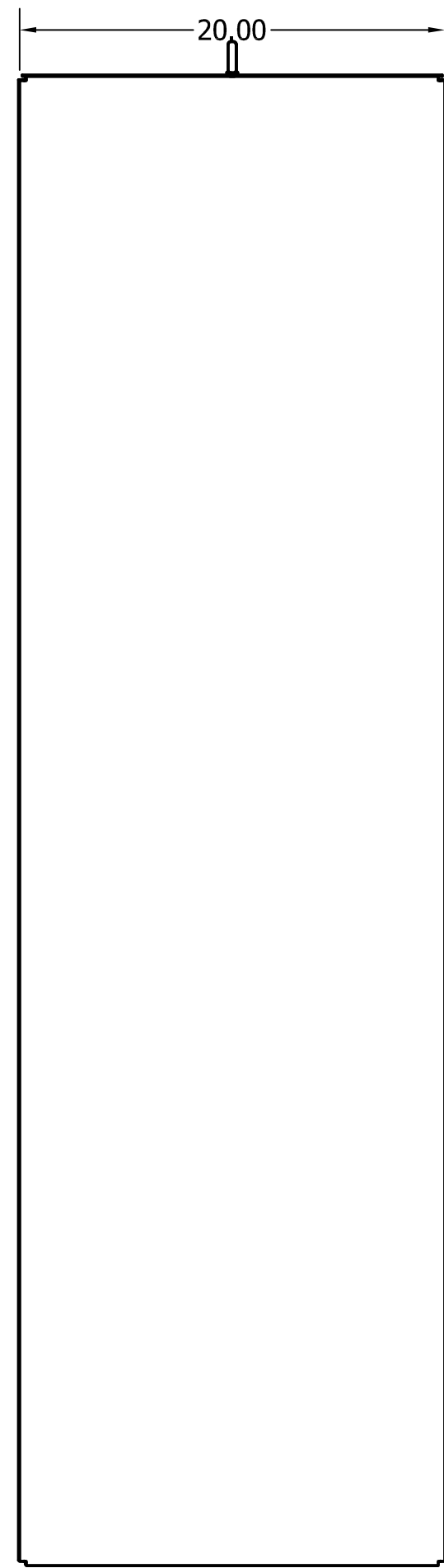

TCI, LLC CLAIMS PROPRIETARY RIGHTS IN THE MATERIAL HEREIN DISCLOSED. IT IS SUPPLIED WITHOUT PREDJUDICE TO ANY PATENT RIGHTS OF TCI AND MAY NOT BE REPRODUCED OR USED TO MANUFACTURE ANYTHING SHOWN THEREIN WITHOUT WRITTEN PERMISSION FROM TCI.

CUSTOMER IS RESPONSIBLE FOR INSTALLATION TO MEET ALL NATIONAL AND LOCAL ELETRICAL CODES.

Material(s) Shall be RoHS Compliant

NO	REVISION	DATE	BY	TOLERANCES (EXCEPT AS NOTED)	DECIMAL	FRACTIONAL	ANGULAR
A	AS DESIGNED	10/5/17	DSW	.XX	+/- .25	+/- 1/16	+/- 1°
				.XXX	+/- .12		

DRN. BY	DATE	DWG. No.
DSW	10/5/17	107291DG
SCALE	APPRVD.	
1/8		SHEET 1 OF 1



W132 N10611 GRANT DRIVE
GERMANTOWN, WI 53022

HGL0200CW1C0000, 600V, 200HP, 3 Phase
HGL0200CW1S0000, 600V, 200HP, 3 Phase
60 Hz, Type 1, Low C, Passive Harmonic Filter