

TCI Performance and Protection for Drives.
KDR Drive Reactor
 TRANS-COIL, INC. MILWAUKEE, WI
 WWW.transcoil.com
 800-824-8282

CATALOG Motor Amps ---
 3% 60Hz, 600V Max. A Max.
 45C 2nd Max. 15C 1st Max.
 Terminal Torque 1/2 IN.

UL LISTED

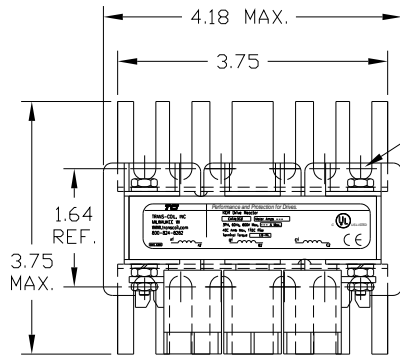

.31" WIDE SLOT

NOTE: A1, A2, B1, B2, C1, C2, MARKINGS ON COIL AND TERMINAL BLOCK FOR REFERENCE ONLY.

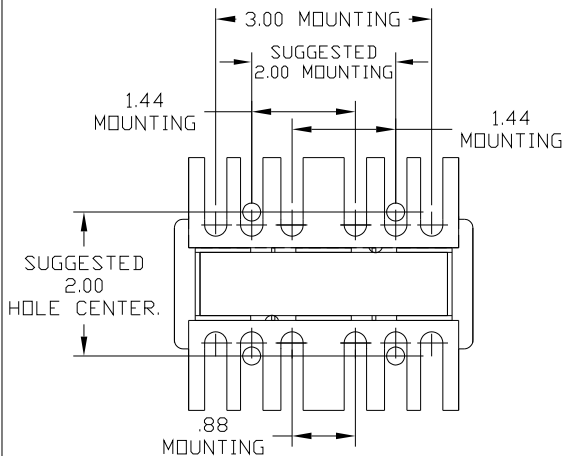
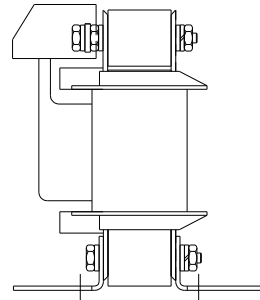
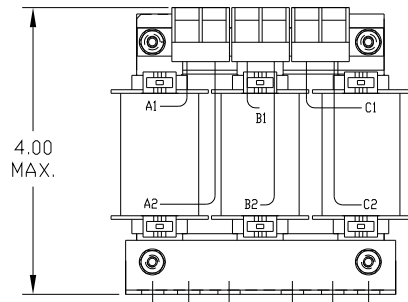
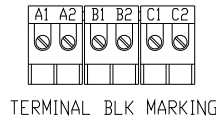

NOTE 1: WATTS LOSS WILL VARY DUE TO FUNDAMENTAL FREQUENCY, CARRIER FREQUENCY AND OTHER SYSTEM CHARACTERISTICS.
 KDR DRIVE REACTORS COMPLY WITH THE THERMAL AND ALTITUDE STANDARDS SET FORTH BY NEMA ST20-1992..

NEC MOTOR CURRENTS SHOWN IN THE 208/240 VOLT CHART ARE BASED ON HORSEPOWER AT 208 VOLT. 575/600 VOLT CHART USE THE 575 VOLT CURRENT RATING.

CATALOG NO	VOLTAGE	NEC MOTOR HP	NEC MOTOR CURRENT	WATTS LOSS	APPROX. WEIGHT-LBS	TORQUE (LB-IN)
KDRULA54L	208/240	0.5	2.40	7	4	10
KDRULA53L	208/240	0.75	3.50	12	4	10
KDRULA25L	208/240	1.0	4.60	11	4	10
KDRULA26L	208/240	1.5	6.60	18	4	10
KDRULA27L	208/240	2.0	7.50	21	4	10
KDRULA28L	208/240	3.0	10.6	29	4	10
KDRULA54H	208/240	0.5	2.40	14	4	10
KDRULA53H	208/240	0.75	3.50	16.8	4	10
KDRULA25H	208/240	1.0	4.60	23.6	4	10
KDRULA27H	208/240	1.5	6.60	30.6	4	10
KDRULA26H	208/240	2.0	7.50	30.5	4	10
KDRULA28H	208/240	3.0	10.6	43.1	4	10
KDRULA55L	575/600	0.5	0.90	6	4	10
KDRULA56L	575/600	0.75	1.30	9.3	4	10
KDRULA50L	575/600	1.0	1.70	12	4	10
KDRULA51L	575/600	1.5	2.40	19	4	10
KDRULA46L	575/600	2.0	2.70	22	4	10
KDRULA52L	575/600	3.0	3.90	23.3	4	10
KDRULA47L	575/600	5.0	6.10	34.7	4	10
KDRULA48L	575/600	7.50	9.0	42.9	4	10
KDRULA49L	575/600	10.0	11.0	43.8	5	10
KDRULA55H	575/600	0.5	0.90	9	4	10
KDRULA52H	575/600	0.75	1.30	13	4	10
KDRULA50H	575/600	1.0	1.70	17	4	10
KDRULA51H	575/600	1.5	2.40	26	4	10
KDRULA43H	575/600	2.0	2.70	24	4	10
KDRULA44H	575/600	3.0	3.90	35	4	10
KDRULA45H	575/600	5.0	6.10	48	4	10

				TOLERANCES (EXCEPT AS NOTED)		7878 N. 86th STREET MILWAUKEE, WI 53224	
				DECIMAL			
				.XX ± .03		KDRUL OPEN (FRAME A) KDR DRIVE REACTOR	
				.XXX ± .010			
				FRACTIONAL		DRN BY DSW DATE 04/23/04 DWG NO. KDRULOPEN-1ADG	
				± 1/16			
				ANGULAR		SCALE 3/4"=1" APPRVD	
				± 1/2°			
NO	REVISION	DATE	BY				