

TCI PERFORMANCE AND PROTECTION FOR DRIVES.
 Trans-Coil, Inc.
 Milwaukee, WI
 www.transcoil.com
 800-824-8282
 KLCUL Output Filter
 KLCUL55A
 3PH, 60HZ, 600V Max, 55A Max
 Dwg #: 101226DG Schematic #: 25389
 Enclosure type: OPEN
 UL US LISTED
 NO. 0018 EB 493
 [DATE CODE]

TCI TRANS-COIL, INC.
 MILWAUKEE, WISCONSIN
 (414) 357-4480
 FAX (414) 357-4484

 dv/dtGUARD
 KLC OUTPUT FILTER

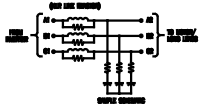
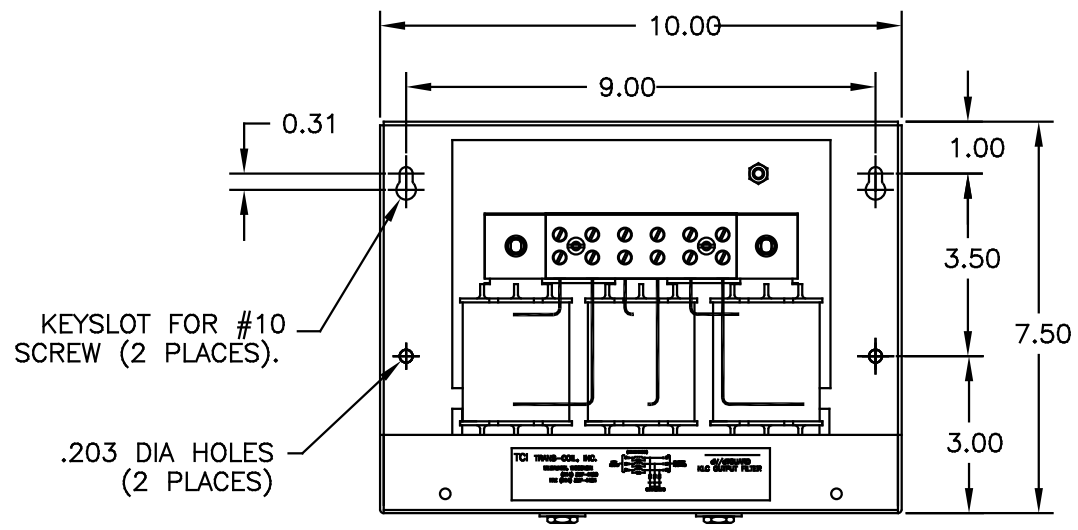
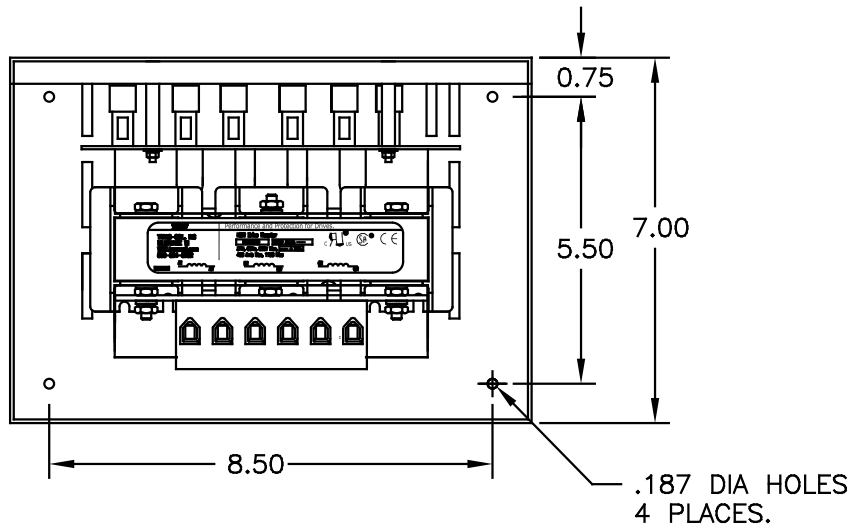
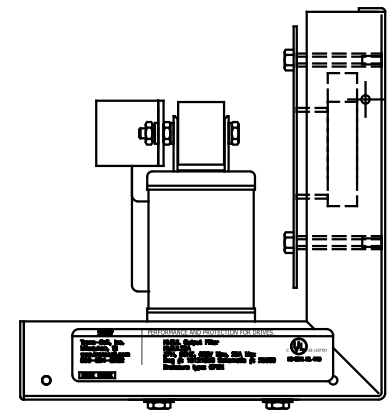

CATALOG NO.	KLCUL55A
VOLTS	480
AMPS	55
KLR PART NO.	KLR55BTB
KLR BOARD NO.	24491
APPROX. WT.-LBS	15
BLOCK WIRE RANGE FOR REACTOR AND TIGHTENING TORQUE.	#18-#4 AWG 20 LB-IN



NOTE: CABINET
 MATERIAL: #16 GA STEEL.
 FINISH: COLOR, BEIGE.

TCI Trans-Coil, Inc. Milwaukee, WI www.transcoil.com 800-824-8282	PERFORMANCE AND PROTECTION FOR DRIVES.	 UL LISTED
	KLCUL Output Filter KLCUL55A 3PH, 60HZ, 600V Max, 55A Max Dwg #: 101226DG Schematic #: 25389 Enclosure type: OPEN	
DATE CODE:		

TCI TRANS-COIL, INC.
 MILWAUKEE, WISCONSIN
 (414) 387-4480
 FAX (414) 387-4484

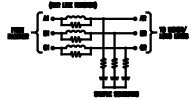

dv/dtGUARD
 KLC OUTPUT FILTER

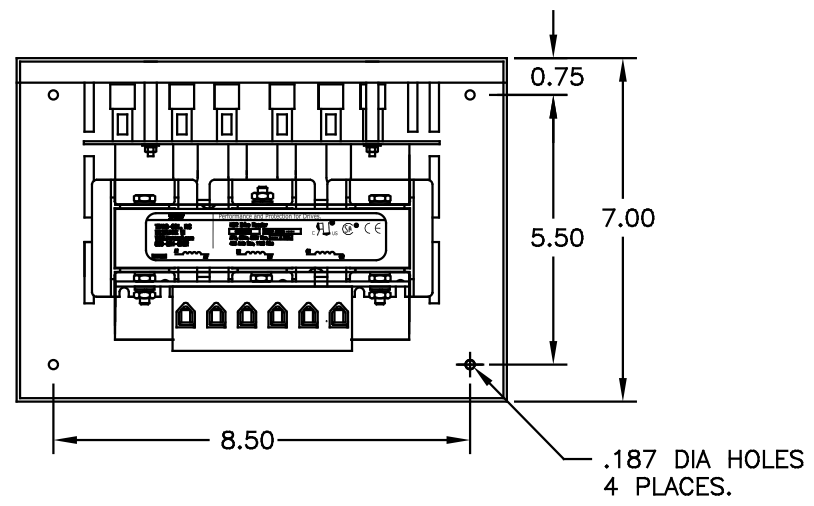

CATALOG NO.	KLCUL55A
VOLTS	480
AMPS	55
KLR PART NO.	KLR55BTB
KLR BOARD NO.	24491
APPROX. WT.-LBS	15
BLOCK WIRE RANGE FOR REACTOR AND TIGHTENING TORQUE.	#18-#4 AWG 20 LB-IN

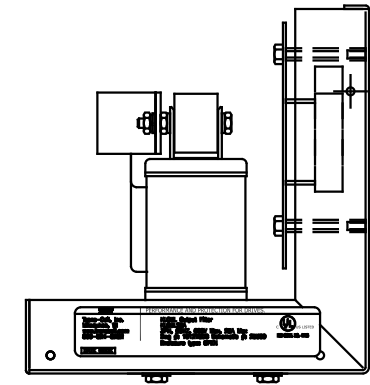
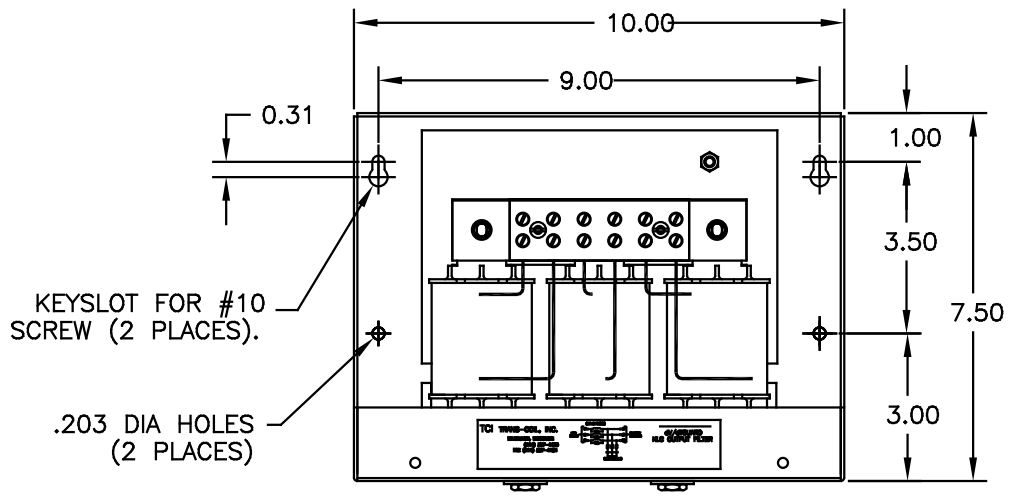

NOTE: CABINET
 MATERIAL: #16 GA STEEL.
 FINISH: COLOR, BEIGE.

CUSTOMER IS RESPONSIBLE FOR INSTALLATION TO MEET ALL NATIONAL AND LOCAL ELECTRICAL CODES

H-2455 UPDATE SCHEM	10/04/06	DSW	TOLERANCES (UNLESS AS NOTED)	 7878 N. 86th STREET MILWAUKEE, WI 53224
G-2413, REMOVE GRD.	2/15/06	DSW	DECIMAL	
F-2326 BOARD UPDATE	07/25/08	DSW	.XX ±.03	TCI, KLCUL OPEN OUTPUT FILTER, 480V, KLCUL55A Dwg #: 101226DG DATE: 03/31/09 DSW SCALE: 1:2 SHEET: 1 OF 1
E-2250, CORRECT WEIGHT	08/28/03	DSW	.XXX±.01	
D-2233, LABEL CHANGE	04/30/03	DSW	FRACTIONAL ± 1/32	
G-2189, CORRECT CAB DIM	07/12/06	DSW	ANGULAR ± 1/2°	
NO	REVISION	DATE	BY	