

TCI PERFORMANCE AND PROTECTION FOR DRIVES.

Trans-Coil, Inc.
Milwaukee, WI
www.transcoil.com
800-824-8282

KLCUL Output Filter
KLCUL8A
3PH, 60HZ, 600V Max, 8A Max
Dwg #: 101208DG Schematic #: 25389
Enclosure type: OPEN

UL LISTED
50 CUL. IN. #13

DATE CODE

TCI TRANS-COIL, INC.
MILWAUKEE, WISCONSIN
(414) 357-4480
FAX (414) 357-4484

dV/dt GUARD
KLC OUTPUT FILTER

WIRING DIAGRAM

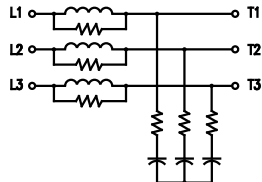

SEE: KLC/KLCUL INSTALLATION GUIDE.
TCI# 25389

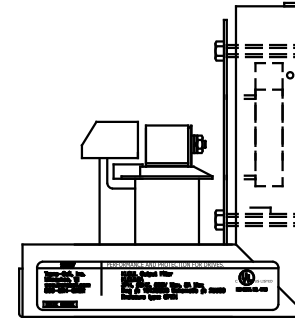
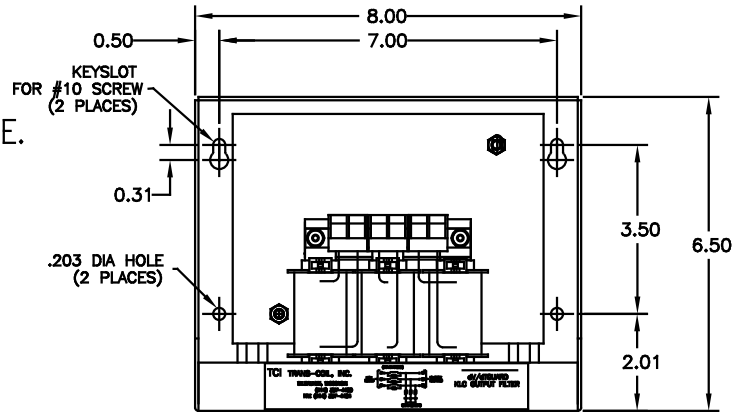
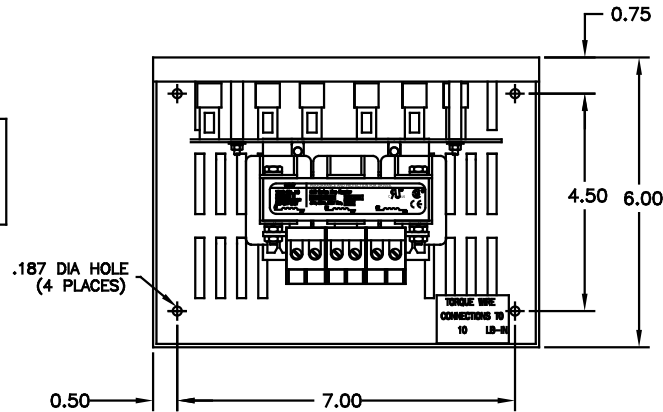

CATALOG NO.	KLCUL8A
VOLTS	480
AMPS	8
KLR PART NO.	KLR8BTB
KLR BOARD NO.	24680
APPROX. WT.-LBS	6
BLOCK WIRE RANGE FOR REACTOR AND TIGHTENING TORQUE.	#12-#18 AWG 10 LB-IN

CUSTOMER IS RESPONSIBLE FOR INSTALLATION TO MEET ALL NATIONAL AND LOCAL ELECTRICAL CODES

NOTE: CABINET MATERIAL: #16 GA STEEL. FINISH: COLOR, BEIGE.

				TOLERANCES (EXCEPT AS NOTED)		TCI 7878 N. 86th STREET MILWAUKEE, WI 53224	
				DECIMAL			
				.XX ±.03		TCI, KLCUL OPEN OUTPUT FILTER, 480V, KLCUL8A	
				.XXX±.01			
				FRACTIONAL		DRN. BY DSW DATE 03-31-00 DRG. NO. 101208DG	
				± 1/32		SCALE 3/8"=1" APPRD. B	
2455 UPDATE SCHEM		10/04/08	DSW	ANGULAR		SHT. 1 OF 1	
NO REVISION		DATE	BY	± 1/2°			