

| VOLTAGE | NEC MOTOR HP | CATALOG NO | NEC MOTOR CURRENT | AMPS MAX | WATTS LOSS | APPROX WT-LBS |
|---------|--------------|------------|-------------------|----------|------------|---------------|
| 690V    | .50          | KDRA55HDRV | .90               | 1.5      | 8          | 4             |
| HIGH-Z  |              |            |                   |          |            |               |

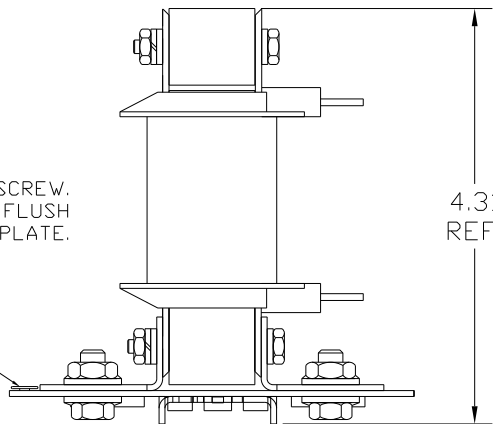

NOTE: CUSTOMER CAN CHANGE MOUNTED REACTOR, FROM VERTICAL TO HORIZONTAL ON DIN BRACKET.

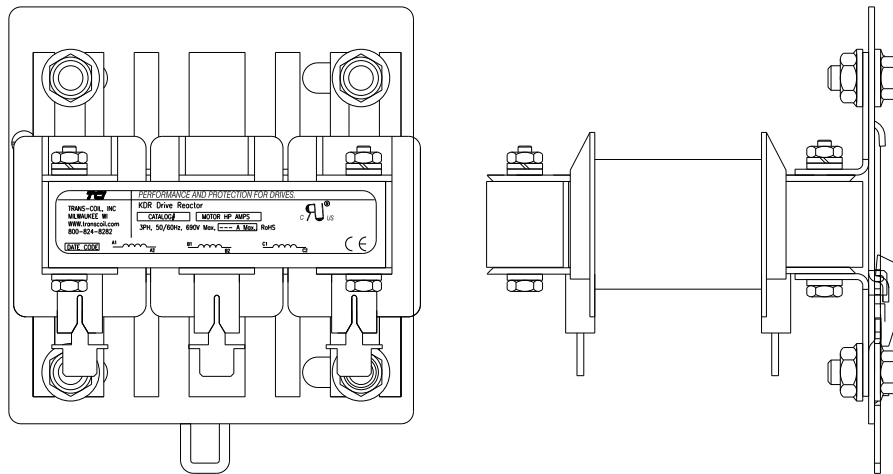

KDR DRIVE REACTORS COMPLY WITH THE THERMAL AND ALTITUDE STANDARDS SET FORTH BY NEMA ST20-1992..

TCI'S DIN RAIL MOUNTED REACTORS FIT STANDARD 35mm DIN RAIL. TCI'S MINIMUM RECOMMENDATION IS TO USE: HIGH PROFILE STANDARD 35mm STEEL RAIL OR HEAVY DUTY STANDARD 35mm STEEL RAIL.

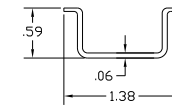

STANDARD STEEL HIGH PROFILE DIN RAIL.

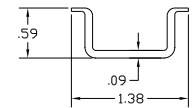

HEAVY DUTY STEEL DIN RAIL.

TCI RECOMMENDS TAKING PRECAUTIONS WHEN SHIPPING MOUNTED REACTORS.

|    |          |      |    | TOLERANCES (EXCEPT AS NOTED) |            | TCI 7878 N. 86th STREET MILWAUKEE, WI 53224 |                                     |
|----|----------|------|----|------------------------------|------------|---------------------------------------------|-------------------------------------|
|    |          |      |    | DECIMAL                      |            |                                             | KDR 690V DIN RAIL FRAME A           |
|    |          |      |    | .XX ± .03                    |            |                                             |                                     |
|    |          |      |    | .XXX ± .01                   |            |                                             |                                     |
|    |          |      |    | FRACTIONAL ± 1/32            |            |                                             |                                     |
|    |          |      |    | ANGULAR ± 1/2°               |            |                                             |                                     |
| NO | REVISION | DATE | BY | SCALE NONE                   | DRN BY DSW | DATE 11/29/2011                             | DWG NO. C KDRA55HDRV DG SHT. 1 OF 1 |