

VOLTAGE	NEC MOTOR HP	CATALOG NO	NEC MOTOR CURRENT	AMPS MAX	WATTS LOSS	APPROX WT-LBS
690V	2	KDRA31PDRV	2.7	4	NOTE:1	4
OUTPUT						

NOTE 1: WATTS LOSS WILL VARY DUE TO FUNDAMENTAL FREQUENCY, CARRIER FREQUENCY AND OTHER SYSTEM CHARACTERISTICS.
 KDR DRIVE REACTORS COMPLY WITH THE THERMAL AND ALTITUDE STANDARDS SET FORTH BY NEMA ST20-1992..

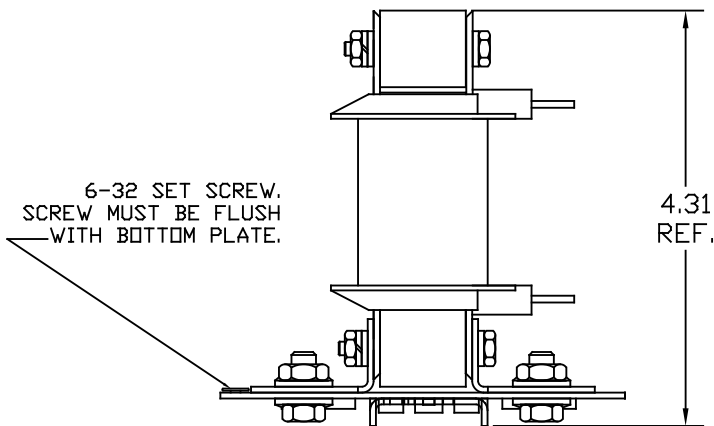

NOTE: CUSTOMER CAN CHANGE MOUNTED REACTOR, FROM VERTICAL TO HORIZONTAL ON DIN BRACKET.

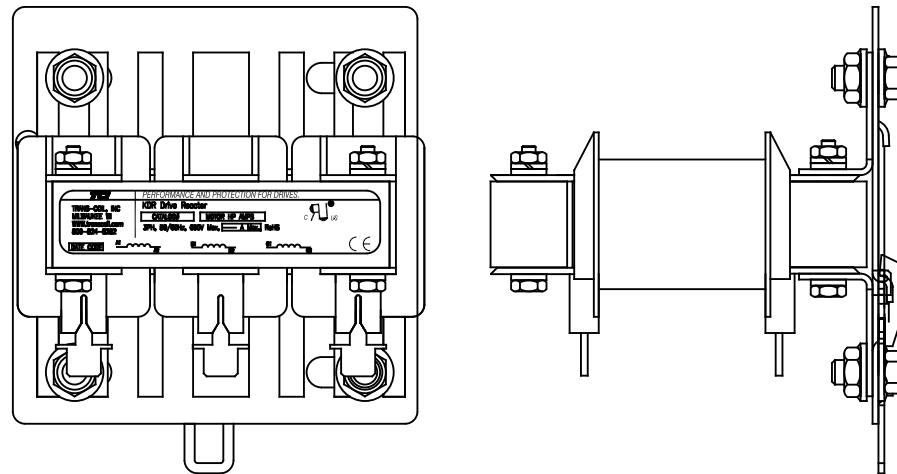

TCI'S DIN RAIL MOUNTED REACTORS FIT STANDARD 35mm DIN RAIL. TCI'S MINIMUM RECOMMENDATION IS TO USE: HIGH PROFILE STANDARD 35mm STEEL RAIL OR HEAVY DUTY STANDARD 35mm STEEL RAIL.

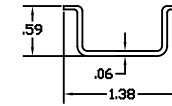

STANDARD STEEL HIGH PROFILE DIN RAIL.

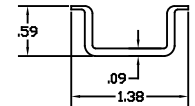

HEAVY DUTY STEEL DIN RAIL.

TCI RECOMMENDS TAKING PRECAUTIONS WHEN SHIPPING MOUNTED REACTORS.

				7878 N. 86th STREET MILWAUKEE, WI 53224	
				KDR DIN RAIL 690V (FRAME A)	
				TOLERANCES EXCEPT AS NOTED DECIMAL .XX ±.03 .XXX±.010 FRACTIONAL ± 1/16 ANGULAR ± 1/2°	DRN BY DSW DATE 03/06/07 DVG NL C KDRA31PDRVJG SHT.1 OF1
NO	REVISION	DATE	BY	SCALE TO FIT	APRVL