

UNIT SPECIFICATIONS:					
KW	HARMONIC	VOLT	HZ	PHASE	FLA
4	5TH	400	50	3	9
ENCLOSURE		WHITE OPEN PANEL			
APPROX.WT. LBS.		38			

SEE 27703 FOR SCHEMATIC

SYMBOL	TCI PART NUMBER
LR	KDRD31T
TR	KTR1L55HG
CAP, 1.. (3 KVAR)	KCAP3A6A
XFMR.	24385
Fu1, 2, 3	18124
Fu4,6	13180
Fu5	13364
CNT	12434

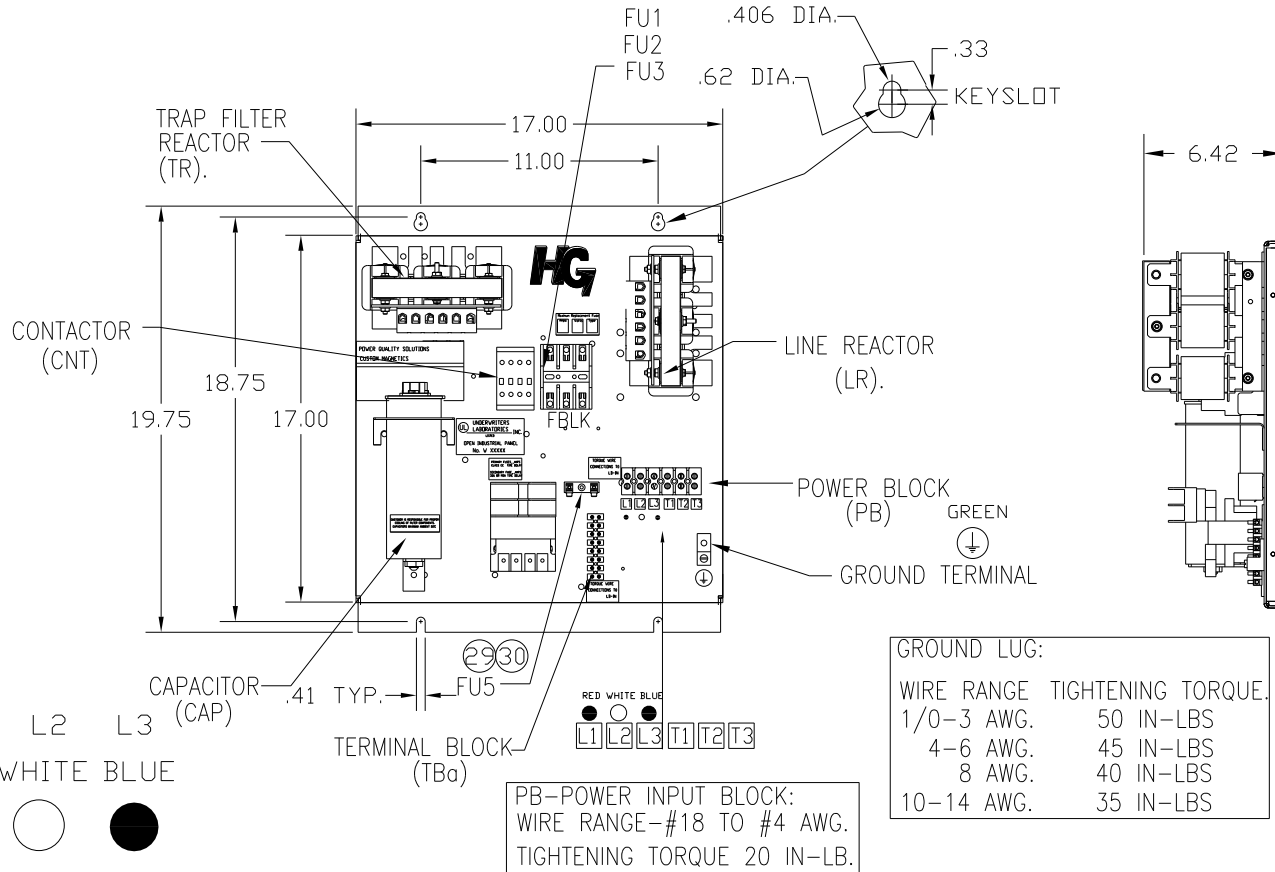

CUSTOMER IS RESPONSIBLE FOR PROPER COOLING OF FILTER COMPONENTS. CAPACITORS MAXIMUM AMBIENT 50°C.

CUSTOMER IS RESPONSIBLE FOR INSTALLATION TO MEET ALL NATIONAL AND LOCAL ELECTRICAL CODES.

TOLERANCES (EXCEPT AS NOTED)				TCI 7878 N. 86th STREET MILWAUKEE, WI 53224	
				HG4LW00STC, 4KW 400/3/50, OPEN	
				DRN. BY	DATE
				DSW	05/11/2011
				SCALE	APRVD
				C 104679DG	
NO	REVISION	DATE	BY	SHT. 1 OF 1	