

HIGH PERFORMANCE  
SINEWAVE OUTPUT FILTER

KMG



### Eliminate harmful $dv/dt$ to result in sinewave output

- Allows Nema MG1 Part 30 motors to be used where Part 31 motors would otherwise be required
- Greatly extend motor and cable life by reduction of motor noise, vibration, and heat
- Specific applications can reach 15,000 feet



HIGH  
PERFORMANCE  
SINEWAVE  
OUTPUT FILTER

# KMG

## Typical Problems, Superior Solutions with KMG

As Pulse Width Modulated (PWM) Drives are incorporated into various applications and processes, the increased energy savings and decreased maintenance on Drives can be offset by increases in Motor failures.

The KMG product family has been designed as an engineered solution for motor failures due to the reflected wave phenomenon.

### *Reflective Wave Phenomenon*

Voltage wave reflection is a function of the voltage rise time (dv/dt) and the length of the motor cables.

The impedance on either end of the cable run does not match, causing voltage pulses to be reflected back in the direction from which it arrived. As these reflected waves encounter other waves, their values add, causing higher peak voltage.

As wire length or carrier frequency increases, the overshoot peak voltage also increases.

Peak Voltages on a 460V system can reach 1200 to 1600V, causing rapid breakdown of motor insulation, leading to motor failure. On 575V systems, the peak voltages can easily reach 2100V. If this is left uncontrolled, insulation failure may occur.

### *Eliminate Reflective Wave*

The KMG filter converts the PWM wave form to a near sinusoidal wave form by eliminating the carrier frequency, allowing sensitive applications to take advantage of the efficiencies and savings that PWM output power supplies and drives offer.

### *KMG filters:*

- Eliminate Torque Ripple
- Eliminate Voltage Wave Reflection
- Can reach 15,000 feet for specific applications
- Reduce Motor Noise, Vibration, and Heat
- Increase Motor Life
- May be used with virtually all AC induction motors, lead lengths and lead types
- Can be used with a wide range of carrier frequencies from 2 kHz to 12 kHz and beyond.

## Voltage Without KMG

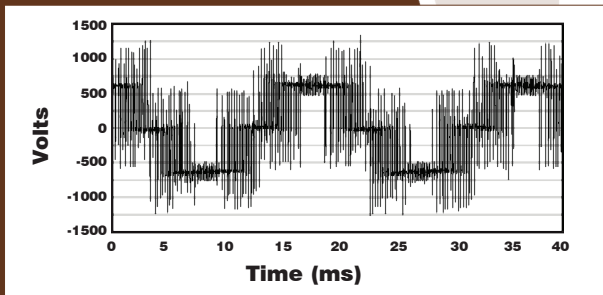

## Voltage With KMG

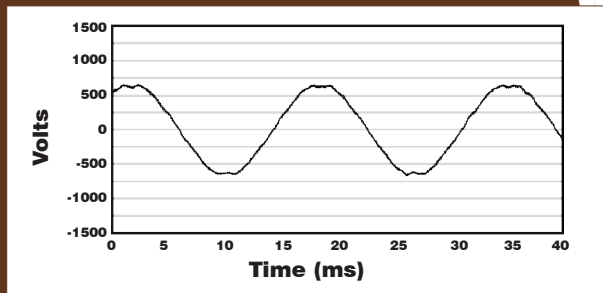

### 508A Industrial Enclosure UL Listed Part Numbering System

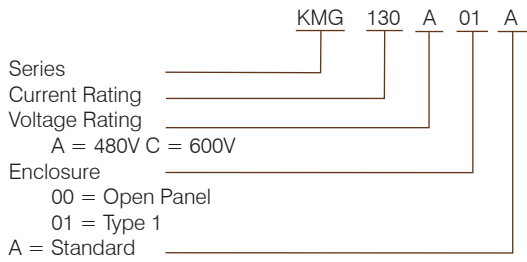

### NEMA General Purpose Part Numbering System

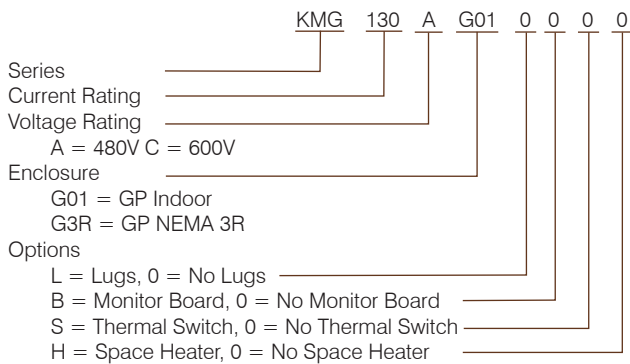

### Low Voltage PWM Power Supply to Medium Voltage Motor



### Block Diagram Test Stand



### Multiple Motor Applications

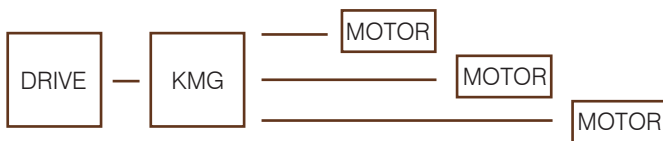

### Extreme Long Lead Applications



### Product Specifications

- Carrier frequencies from 2 kHz to 12 kHz
- Short Term Overload Rating: Tolerance 200% rated I for a minimum of 3 minutes
- System Voltage: 480 VAC, 600 VAC
- Insulation System: Class H (180° C) or Class R (220° C)
- Temperature Rise: 115° C or 155° C
- Ambient Temperature:  
Open Panel 50° C (122° F)  
Enclosed Panel 40° C (104° F)
- Distance: up to 15,000 feet
- Voltage Distortion: < 5% (typical)
- Agency Approvals: Industrial - cUL, UL
- Enclosures:  
Industrial Version: UL Open, UL Type 1  
General Purpose: NEMA 1 and 3R

### PERFORMANCE GUARANTEE

Properly sized and applied, the addition of a KMG Output Filter is guaranteed to bring the application into compliance with NEMA Standards Publication No. MG-1. If the system fails to meet MG-1 standards with the addition of a KMG filter, TCI will take back the output filter and pay shipping both ways. This offer is valid for 60 days from purchase date.



Reliable  Advanced Power Quality

#### KMG TYPICAL APPLICATIONS

- Extreme long motor lead lengths. Applications can reach 15,000 feet
- Low voltage PWM power supply to medium voltage motor
- Multiple motor applications such as conveyors, blowers, pumps, and fans
- Test floor and test stand applications
- Shore to ship power for non-60 Hz systems
- HVAC systems to reduce audible noise

## Additional Power Quality Solutions:



### *KDR Line Reactor*

- Prevents nuisance tripping
- Protects the source by lowering current distortion created by the drive



### *HG7 Passive Harmonic Filter*

- Helps meet IEEE-519
- Reduces harmonic distortion to less than 7% TDD at full load
- Improves power factor



### *H5 Active Harmonic Filter*

- Helps meet IEEE-519
- Reduces harmonic distortion to less than 5% TDD at full load
- Actively monitors the load current while returning the power factor to near unity



### *KRF EMI/RFI Filter*

- Filter EMI/RFI noise caused by power switching devices
- Meet FCC regulation 15, subpart 3
- Prevents interference with automated lighting circuits, security cameras, and other critical electronics



### *V1k Motor Protection Output Filter*

- Protects the motor and cable from voltage spikes due to high dv/dt and excessive cable capacitance
- Helps stop motor insulation breakdown
- Protects cable runs (up to 3,000 feet) and reduces motor heating, noise and vibration